

HD ELITE BALANCER

Heavy-duty Diagnostic Balancer

OPERATIONS MANUAL



Standard Operation Video



Form: BM08069-00
10/10/2024
Supersedes 06-24

Table of Contents

1. Getting Started	4
1.1. Introduction	4
1.1.1. Corporate Information	4
1.2. Safety Instructions	4
1.3. Electrical	5
1.4. Decal Information	5
1.5. Precautions	7
1.6. Power Switch	8
1.7. Equipment Specifications	9
1.7.1. Explanation of Symbols	9
1.8. HD Elite® Main Screen Components	10
1.9. HD Elite Components	11
2. Operating the Balancer	12
3. Balancing Procedures	15
3.1. Wheel Lift Operation	15
3.2. CenteringCheck® & Collet Mounting	15
3.3. Specialized Mounting Conditions	17
3.4. Wheel Assembly Selection for Saving Spin Data	21
3.5. Balance Modes	22
3.6. Motor Drive / Servo-Stop and Spindle-Lok	23
3.7. Safety Hood Features	24
3.8. Balancing Procedures for Specific Weight Types & Placement using TruWeight™	24
3.8.1. Balancing Procedure Using Clip-On Weights	25
3.8.2. Balancing Procedures Using a Combo of Clip-On & Adhesive (Tape) Weights (Mixed Weights)	27
3.8.3. Balancing Procedure Using Adhesive (Tape) Weights	28
3.9. Rim Dimension Manual Entry	30
3.9.1. Rim Dimension Manual Entry - Tape/Tape	30
3.9.2. Rim Dimension Manual Entry - Clip/Clip	31
3.9.3. Blinding and Rounding	31
3.9.4. Tape Weight Menu & Split Spoke Feature	32
3.10. Patch Balance® Mode	32
3.11. Optional HammerHead TDC Laser Clip-On Weight Locator	34
3.12. TPMSpecs™ Feature & Hunter Help	35
4. SmartWeight® Balancing	38
4.1. SmartWeight Balancing Technology	38
4.2. SmartWeight® Balancing Technology Dynamic Weight Planes	38
4.3. Using SmartWeight® Balancing Technology	39
4.4. Switching from SmartWeight® Balancing to Traditional Dynamic Balancing	40
4.5. Switching from Traditional Dynamic Balancing to Traditional Static Balancing	40
5. ForceMatching Measurement® Procedures	42
5.1. Load Roller Operation	42
5.2. Forcematching®	42
5.2.1. Match Codes	44
5.2.2. Encountering Forcematch® Prediction Errors	46
5.2.3. Do's and Don'ts of Road Force Measurement	47
5.2.4. ForceMatch® Savings	47
5.3. ForceMatch & SmartWeight Savings	47
6. Optional Balancer Procedures	48
6.1. Tools	48
7. Maintenance	50
7.1. Calibration Procedures	50
7.2. Cleaning the Console	50
7.3. Cleaning and Lubricating the Adjustable Flange Plate and Pin	51
7.4. Maintenance Schedule	52

1. Getting Started

1.1. Introduction

This manual provides operation instructions and information required to operate the HD Elite Balancer. Read and become familiar with the contents of this manual prior to operating the HD Elite Balancer.

The owner of the HD Elite Balancer is solely responsible for arranging technical training. The HD Elite Balancer is to be operated only by qualified trained technicians. Maintaining records of personnel trained is solely the responsibility of the owner and management.

This manual assumes the technician has already been trained in basic balancing procedures.

1.1.1. Corporate Information

Hunter Engineering Company

Addr:	11250 Hunter Drive, Bridgeton, MO 63044 USA
Ph:	314-731-3020
Web:	www.hunter.com

References

This manual assumes that you are already familiar with the basics of tire balancing.

1.2. Safety Instructions

Read all instructions before operating the HD Elite Balancer. Read and follow the instructions and warnings provided in the service, operation and specification documents of the products with which this HD Elite Balancer issued (i.e., automobile manufacturers, tire manufacturers etc.).

Do not operate equipment with a damaged cord or equipment that has been dropped or damaged until a Hunter Service Representative has examined it. Always unplug equipment from electrical outlet when not in use.

Never use the cord to pull the plug from the outlet. Grasp plug and pull to disconnect. If an extension cord is necessary, it must have a current rating equal to or more than that of the equipment. Cords rated for less may overheat. Arrange the cord so that it will not be tripped over or pulled.

Verify that the electrical supply circuit and the receptacle are properly grounded. To reduce the risk of electrical shock, do not use on wet surfaces or expose to rain. Verify the appropriate electrical supply circuit is the same voltage and amperage ratings as marked on the balancer before operating.



DANGER

DO NOT ALTER THE ELECTRICAL PLUG. Plugging the electrical plug into an unsuitable supply circuit will damage the equipment and may result in personal injury.

To reduce the risk of fire, do not operate equipment near open containers of flammable liquids (gasoline). Read and follow all caution and warning labels affixed to your equipment and tools. Misuse of this equipment can cause personal injury and shorten the life of the balancer. Keep all instructions permanently with the unit.

Keep all decals, labels, and notices clean and visible. To prevent accidents and/or damage to the balancer, use only Hunter HD Elite Balancer recommended accessories. Use equipment only as described in this manual. Never stand on the balancer. Wear non-slip safety footwear when operating the balancer.

Keep hair, loose clothing, neckties, jewelry, fingers, and all parts of body away from all moving parts. Do not place any tools, weights, or other objects on the safety hood while operating the balancer.

ALWAYS WEAR OSHA APPROVED SAFETY GLASSES. Eyeglasses that have only impact resistant lenses are NOT safety glasses.

Keep the safety hood and its safety interlock system in good working order. Verify that the wheel is mounted properly and that the wing nut is firmly tightened before spinning the wheel. The safety hood must be closed before touching the green "START" button, to spin the wheel.

Raise safety hood only after wheel has come to a complete stop. If safety hood is raised before the spin is completed, the weight values will not be displayed. Do not let cord hang over any edge or contact fan blades or hot manifolds. The red "STOP" button, can be used for emergency stops.



DANGER

Never reach under the hood while the balancer is performing a run out measurement or balance spin.

1.3. Electrical

The Hunter HD Elite Balancer is manufactured to operate at a specific voltage and amperage rating. Make sure that the appropriate electrical supply circuit is of the same voltage and amperage ratings as marked on the balancer.



DANGER

DO NOT ALTER THE ELECTRICAL PLUG. Plugging the electrical plug into an unsuitable supply circuit will damage the equipment.

Make sure that the electrical supply circuit and the appropriate receptacle is installed with proper grounding. To prevent the possibility of electrical shock injury or damage to the equipment when servicing the balancer, power must be disconnected by removing the power cord from the electrical power outlet.

After servicing, be sure the balancer ON/OFF switch is in the "O" (off) position before plugging the power cord into the electrical power outlet. This device is rated as Class A for radiated emissions. In the event of radio interference, the display read out may flicker - this is normal.

1.4. Decal Information

RIGHT SIDE VIEW

Decal HD Elite 28-HD Elite 244-2 cautions the operator that spindle rotation may occur with foot pedal depression and to keep clear of clamping components during shaft rotation.

Decal HD Elite 28-964-2 gives the maximum wheel diameter and maximum wheel weight for the HD Elite.

EN/IEC Class HD Elite Laser Product Certification is shown on Decal **HD Elite 28-HD Elite 638-2**. This label shows the EN/IEC standards for a Class HD Elite Laser Product.

An explanation of FDA compliance standards is shown on Decal **HD Elite 28-HD, Elite HD Elite 7-2**. FDA performance standards compliance is shown on the decal.

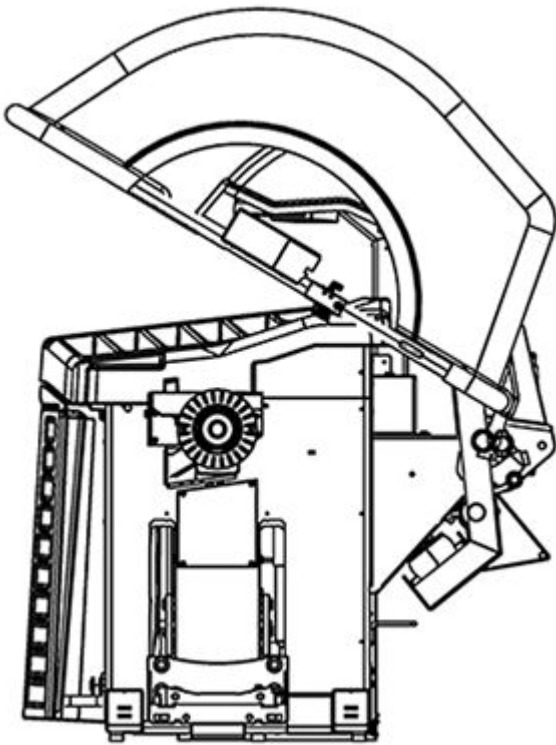

FRONT VIEW

FDA standards for Class 2M laser compliance are shown on Decal **HD Elite 28-HD, Elite HD, and Elite 55-2** (for TDC Units).

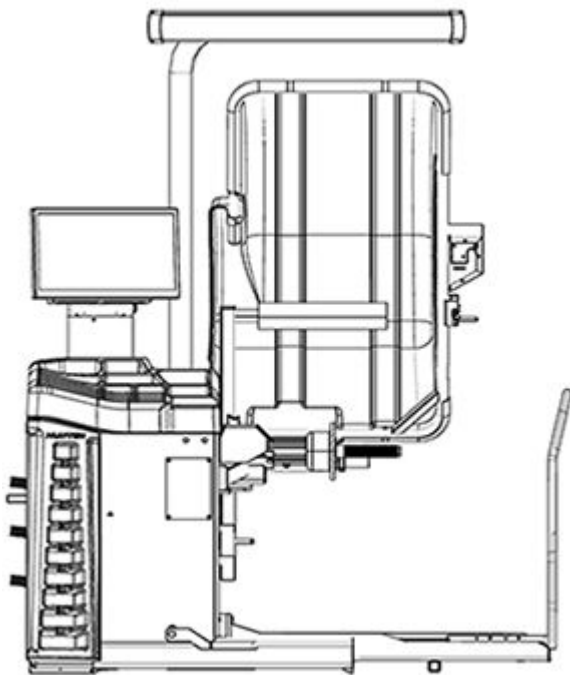

LEFT SIDE VIEW

Decal **HD Elite 28-39HD Elite-2-00** cautions that the unit may automatically start upon closing of the hood when Hood Autostart is enabled.

The Class 2M laser apertures are located at either end of the TDC header.



Decal HD Elite warns the operator not to remove the cover of the HD Elite because of the risk of electrical shock and not to use below garage floor level.

ETL certification standards are outlined on Decal HD Elite. Additionally, users are cautioned not to use the balancer below garage floor level.

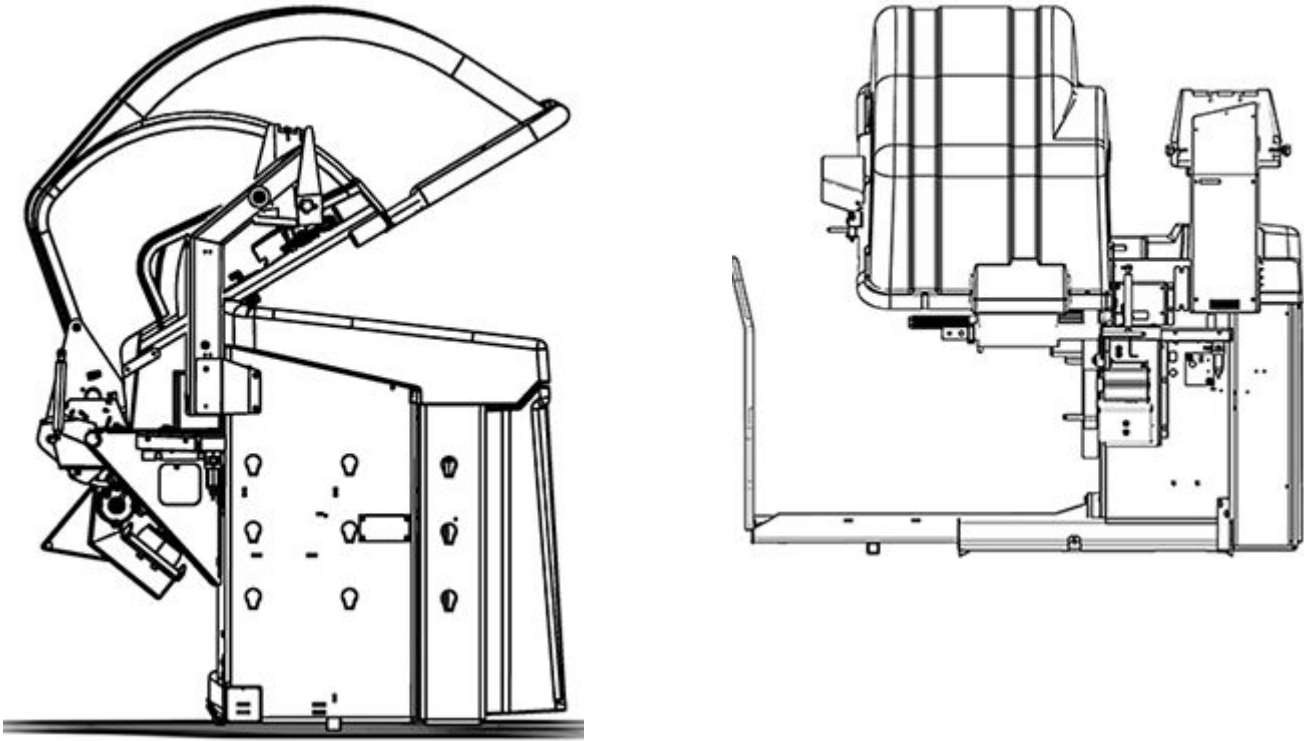

A manufacturer's identification label is also on the rear of the balancer.

1.5. Precautions

POWER SOURCE

The HD Elite Balancer is intended to operate from a power source that will apply 230VAC +10% / -15%, 10amp 50/60 Hz, power cable includes NEMA 20 amp plug, L6-20P, between the supply conductors of the power cord.

The power cord supplied utilizes a twist lock connector, NEMA L6-20P. This machine must be connected to a 20 amp branch circuit. Please refer all power source issues to a certified electrician.

Short-circuit current rating (SCCR) of the electrical equipment is 5 kA.

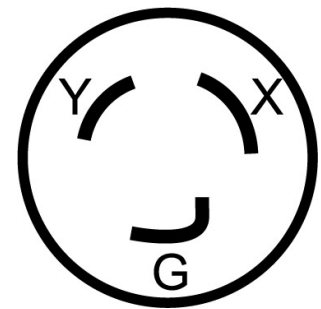

CAUTION

A protective ground connection, through the grounding conductor in the power cord, is essential for safe operation. Use only a power cord that is in good condition.



NOTE

For information on converting from single phase NEMA L6-20P plug to three phase NEMA LHDElite5-20P plug refer to Form 5350-T

OPTICAL SCAN LASER

The Optical Scan Laser is a class HD Elite laser designed to measure the profile of wheel assemblies. The laser is not a field serviceable part. No maintenance is to be performed on the laser.

Wavelength: 650nm.

HAMMERHEAD® TDC LASER INDICATOR (Optional)

The TDC (Top Dead Center) Laser Indicator is a class 2M laser designed to aid in applying clip-on weights. The laser is not a field serviceable or adjustable part.

Use caution in regard to reflective materials around the laser and never look into the laser beam.

LASER RADIATION - DO NOT STARE INTO THE BEAM OR VIEW DIRECTLY WITH OPTICAL INSTRUMENTS.

Viewing the laser output with magnifiers or related optical instruments within a distance of 100mm from the laser aperture may pose an eye hazard.

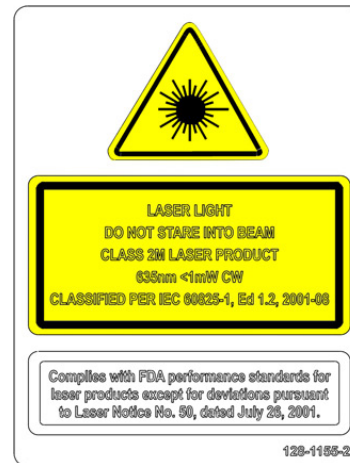

1.6. Power Switch

TURNING POWER ON/OFF

Push Button

The HD Elite power button is located on the left side of the LCD support. Use this switch for normal shut down and restarting procedures.

MAIN POWER SWITCH

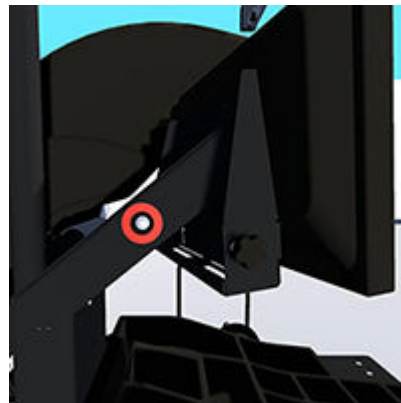

The main power switch is located on the back of the balancer. To power the balancer "ON," press the "I" side of the ON/OFF switch. To turn all power the balancer" OFF," press the "O" side of the ON/OFF switch.



CAUTION

Always use the power button on the LCD support turn on/off in order to prevent data loss.



Following a self-check, the main balance screen will appear indicating the unit is ready for use.

1.7. Equipment Specifications

Only a Hunter Factory-Authorized Representative should perform installation. This equipment contains no operator serviceable parts. All maintenance and repairs must be referred to a qualified Hunter Service Representative.

Table 1. Equipment Specifications

Electrical	
Voltage:	208-240V, 3 amp, 50/60 Hz, 1 ph (NEMA 20 amp plug, L6-20P)
Amperage:	10 amperes
Wattage:	3450 watts (peak)
Air	
Air Pressure Requirements:	100-175 PSI (7-12 bar)
Approximate Air Consumption:	4 CFM (110 Liters/Minute)
Atmospherics	
Temperature:	+32°F to +122°F (0°C to +50°C)
Relative Humidity:	Up to 95% Non-condensing
Altitude:	Up to 10,000 ft. (3048 m)

1.7.1. Explanation of Symbols

	Alternating Current
	Earth ground terminal
	Protective conductor terminal
	ON / OFF (Supply) condition
	Risk of electrical shock
	Stand-by Switch



Not intended for connection to public network

1.8. HD Elite® Main Screen Components



Table 2. Main Component Legend

1. Tire Stack / Vehicle Plan View Tab	9. Imbalance and Couple Force Display
2. Load Roller (if installed)	10. SmartWeight Savings Odometer
3. Clip Weight Plane	11. ForceMatch Savings Odometer
4. Tape Weight Plane	12. ForceMatch Display
5. Context Sensitive Menu	13. ForceMatch Wheel Assembly Display
6. Wheel Assembly Display	14. ForceMatch Button
7. Start / Stop / Servo Button	15. eCal Button
8. SmartWeight® Menu Button	16. Wheel Dimension Tab

1.9. HD Elite Components

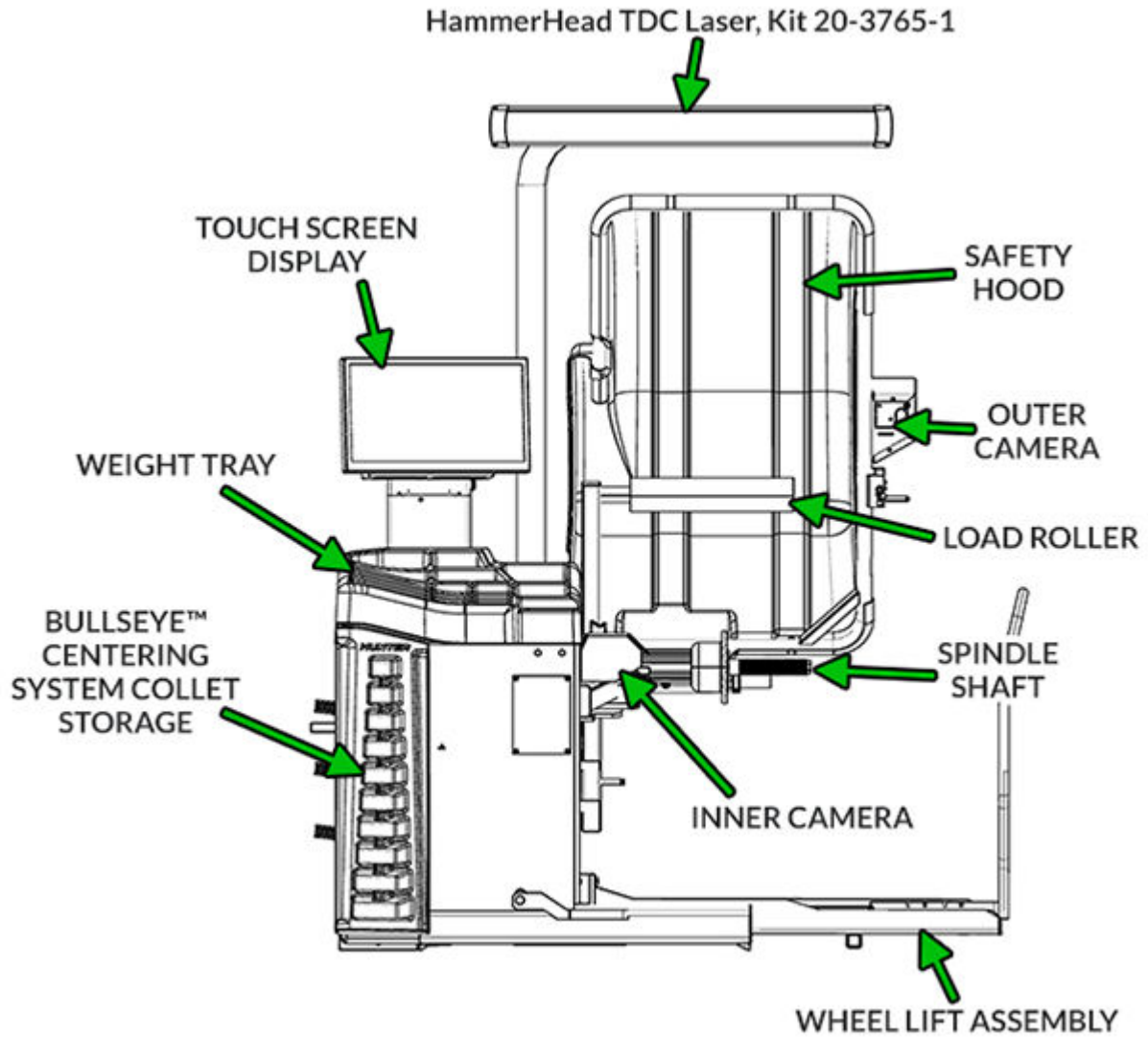

2. Operating the Balancer

Main Balance Screen

Pull-out tabs are on the left for Tire Stack/Vehicle Information (upper tab) and Wheel Dimensions (lower tab). Buttons along the right side allow navigation to other screens and activities. Buttons in the lower left and right portions of the screen allow navigation to Force Match® and SmartWeight® procedures and options.



Main Balance Screen - Error Pop-ups

If the operator attempts to perform an illegal operation in the main balance screen, an error pop-up with appropriate information will be displayed. For example, the above screen is displayed if operator attempts to start a spin without first lowering the hood.



Main Balance Screen - "Tire Rash"

After a ForceMatch® spin, a colored road rash will appear on the tire. This signifies the measured Force Match® of the assembly, and corresponds to the value and color presented in the Force Match® animation in the lower left portion of the screen.



Main Balance Screen - Prompt Text

When the operator needs more info in a non-error condition, prompting text will appear in the lower portion of the screen.



Main Balance Screen – Enable and Disable Load Roller

To enable or disable the load roller in the main balance screen, touch the load roller on the screen to cycle through all available options.



Main Balance Screen – Inflation Station

When the operator attempts a loaded balance spin, and if “Prompted Inflation Station” is enabled in Setup, the operator will be prompted to answer if the tire has been inflated to the manufacturer’s specification.



Main Balance Screen – Performing a Spin

During a loaded balance spin, several things occur on the screen. First, the green Start button is replaced with a red Stop button and the tire assembly spins in 3D space. As soon as the balance portion of the spin is complete, weights will appear on the screen.

During each portion of the loaded spin, the text in the lower portion of the screen will alert the operator about what is being measured.

After the loaded spin is complete, and if dimensions have been entered, the 3D scene will show all information necessary to balance the assembly including; Assembly Force, Weight Amounts, Weight Type, and Weight Position.



Main Balance Screen – Servoing To Position

If servoing is enabled in Setup, the balancer will servo either the inner or outer place weight position to top dead-center. To servo to the next position, the operator can either touch the “Servo” button or touch the corresponding weight amount.



Main Balance Screen – Force Match® Buttons

Touching the Force Match® button expands a set of button options. The load roller can be disabled/enabled. The operator can change the Force Match® limits. The “Show Savings” button can show detailed views of the cost savings from Force Match® balancing. And finally, the operator can select one of three Force Match® procedures: Force Matching® and HD Elite80 Matching. Display of historical data is also available.



Main Balance Screen – SmartWeight® Buttons

Touching the SmartWeight® button expands a set of button options. SmartWeight® can be disabled or enabled, Performance Mode can be disabled or enabled and Weight savings can be viewed.



3. Balancing Procedures

3.1. Wheel Lift Operation

Raising the Wheel Assembly



CAUTION

When operating the wheel lift, make sure to maintain two-handed control of the wheel assembly.

Slide the appropriate Bullseye™ Centering System collet onto the spindle shaft.

1. Position wheel lift carriage at the end of the wheel lift rail.
2. Press the lift control handle “down” until the trolley carriage is at its lowest level.
3. Roll the wheel assembly onto the wheel lift carriage.
4. Raise the lift control handle “up” to move the lifting assembly into a position where the wheel assembly can be installed onto the spindle shaft.
5. Slide the tire/wheel assembly onto the spindle and center on the collet. Verify that the wheel assembly is centered vertically on the spindle shaft.



NOTICE

Lower wheel lift as needed to clamp wheel, but keep the wheel lift carriage in place under the wheel assembly.

6. Clamp wheel onto the spindle shaft.
7. Keep the wheel lift carriage in place under the wheel assembly and close the hood. The lifting assembly will automatically lower and park the carriage below.



NOTICE

Allowing the balancer to park the wheel lift carriage in place under the wheel assembly will make the removal and lowering of wheel assembly easier and quicker.

Lowering the Wheel Assembly

1. Remove the clamp
2. Starting with the wheel lift carriage parked under the wheel assembly; raise the lift control handle “up” to move the lifting assembly to the wheel assembly.
3. Release the lift control foot pedal when the assemblies contact one another. Remove the wheel clamp
4. Slide the carriage with wheel assembly to the end of the wheel lift rail.
5. Press the lift control handle “down” until the carriage is at its lowest level. Roll wheel assembly from carriage.

3.2. CenteringCheck® & Collet Mounting

CenteringCheck® is an inspection or verification of the wheel’s mount to balance to identify possible centering errors, thus recognizing improper measurements.

From the main balance screen, touch the “CenteringCheck” button and follow the on-screen instructions.

FRONT / BACK COLLET MOUNTING

Collet mounting is one of the most common and reliable ways to mount wheels on balancers.

The Bullseye® Centering System is a set of collets that provides wheel centering coverage for most passenger cars and light trucks. Due to the degree of taper on the collets, multiple collets may be used on a wheel assembly. As long as the collet is in the center bore of the wheel, and does not bottom out, it can be used. To verify, always perform a centering check.

Select the proper Bullseye® Centering System collet by placing it in the center bore of the wheel to be balanced. Select the collet that contacts the wheel nearest the center of the collet.

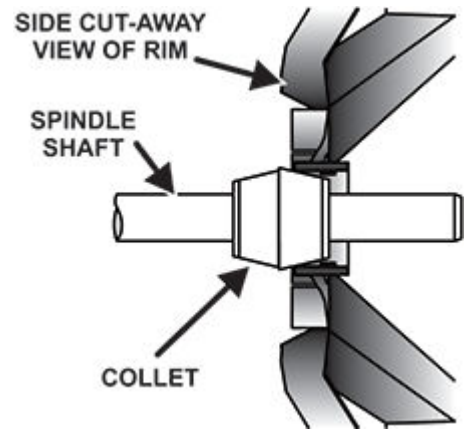

Using The Plastic Wheel Mounting Spacer

The plastic wheel mounting spacer, 46-320-2, may be used to prevent scratches on wheels where the standard plastic cup and scratch guard cannot be used.

The plastic wheel mounting washer may also be used when mounting a wheel with a large offset that is between collet sizes. Use of the washer as shown below can improve centering ability by increasing cone pressure against the wheel.

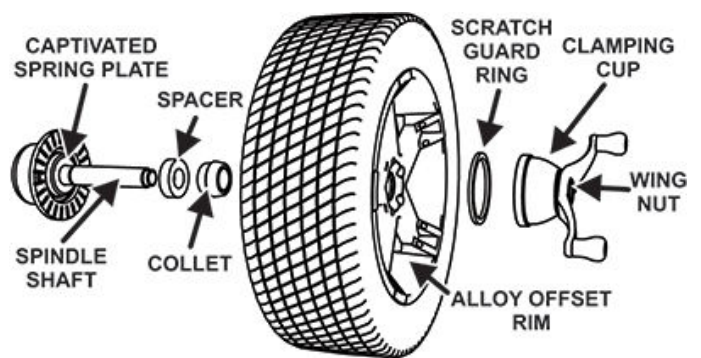
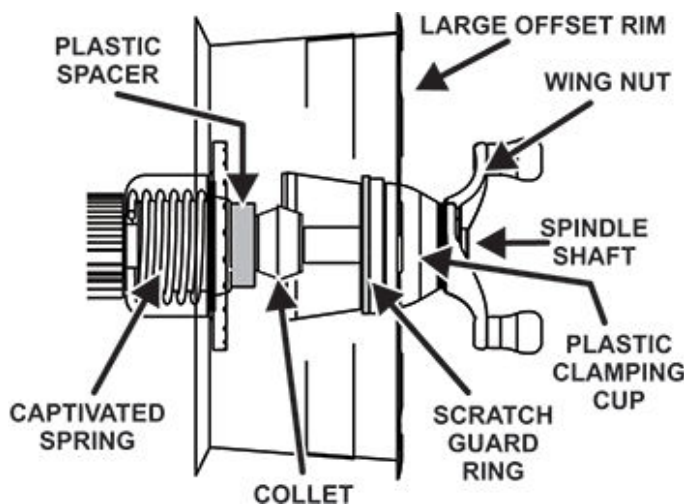

Using The 9-Inch Alloy Wheel Pressure Cup

In some cases, the wing nut contact point of the wheel may be extremely wide, and the standard clamp cup will not properly contact the wheel hub area. In these cases, the optional nine inch alloy wheel pressure cup may be used in place of the clamping cup.

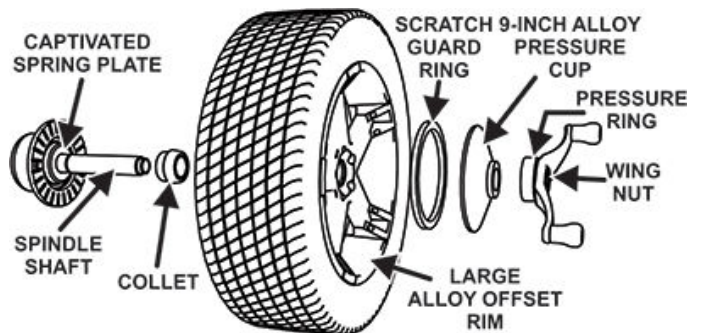

Front Collet Mounting



NOTICE

Front collet mounting is generally **not recommended**. It should only be used in instances where traditional backside collet mounting is not possible.

This procedure utilizes a collet inserted from the front side of the wheel instead of the backside as previously described.

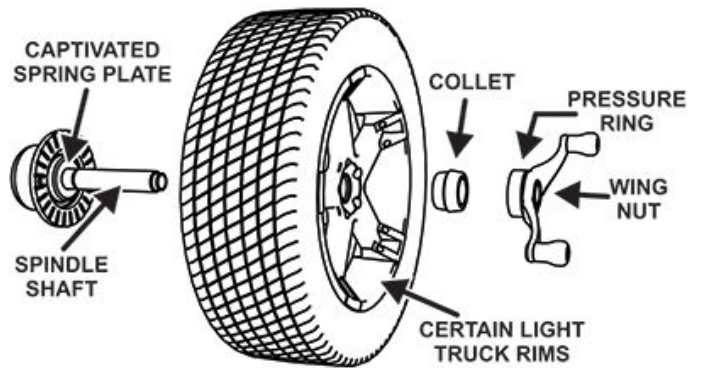

Heavy Wheel Centering

Heavy wheel centering may benefit by (1) pulling the tire away from the hub face at top dead center while tightening the wing nut or (2) use of optional wheel lift to position heavy wheel onto shaft and cone. This helps the wheel to overcome gravity against the hub or spacer.

3.3. Specialized Mounting Conditions

Collet / Flange Plate Mounting

Some wheels may be centered using the lugholes and center bore with a flange plate and collet. It is important that a back mounted collet be used to support and center the wheel when using flange plates.

Flange plates are useful when the wheel cannot be properly centered off the hub bore with a collet alone because of improper fit, interference, or lack of a center hole.

Insert Index Pin into the Flange Plate as follows:

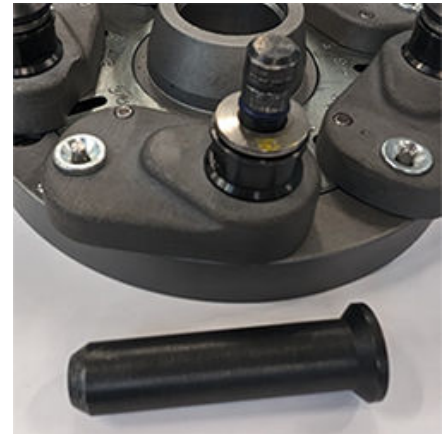

To remove, push down on silver latch button and pull up on the pin at the same time.

If more than one intersecting slot is present, use the one located in the center of the slot.

Push down on the pin and rotate a quarter turn to lock in place. Repeat pin installation to fill each of the correctly numbered slots.

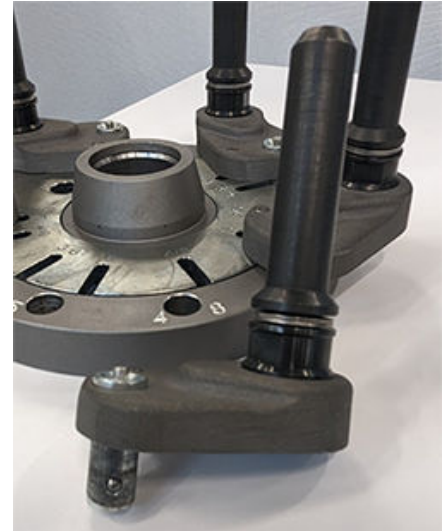
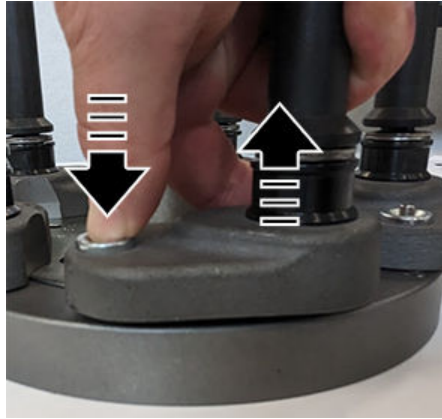

1. Align the index slot in the hub with the index slot in the guide. On the hub, the one slot NOT numbered (located between the two 1-inch holes) is the index slot. On the guide, the one slot NOT grouped with the other slots is the index slot.
The thumbscrew through the side of the flange plate limits the movement of the guide plate to keep the two index slots crossing each other.
 2. Hold the adjustable flange plate with the hub (numbered slots) on facing you.
 3. Insert a pin assembly, 20-3689-1, into the index slots as follows:
Turn the guide to center the intersection of the two index slots. Align the tab at the end of pin to the index slot in hub.
Insert the end of pin through the intersecting index slot in the guide. Push down on the pin and rotate the pin a quarter turn to lock in place.
4. A pin is inserted in the index slot for every wheel, regardless of the number of lugs.
 5. Along with the index pin, insert additional pin assemblies, 20-3689-1, into each of the correctly numbered slots as follows:
 - Turn the guide to locate the index pin near the center of index slot.
 - Align the tab of the pin assembly to the numbered slot. Insert the end of pin assembly through the slot and into the intersecting slot of the guide.

Set Flange Plate for a Wheel as follows:

**WARNING**

DO NOT pry or hammer stuck pins from adjustable flange plate.

**NOTICE**

For Ford 7 X 150 mm lug pattern, align the index pin to the 150 mm mark and insert the remaining six pins, 20-3689-1, into the #7 slots. Insert the end of pin through the 3/16 inch holes in the guide plate.

The correct flange adaptor setup is determined by the following:

Measure and set the bolt circle diameter and number of studs to use against the lug holes.

Set the number of lugholes as follows:

- A three-lug wheel uses three studs.
- A four-lug wheel uses four studs.
- A five-lug wheel uses five studs.
- A six-lug wheel uses three studs.
- A seven-lug wheel uses seven studs.
- An eight-lug wheel uses four studs.

Choose the correct taper design of flange studs to fit the wheel lug seats. The mounting area of the flange stud must match the design of the wheel's lughole seat or depression.

The flange plate must be able to apply pressure to the center of the wheel while maintaining perpendicularity to the shaft.

**NOTICE**

If the lug seats are unevenly machined or worn, an optional universal flange adaptor with compressible studs or bolt on lugs may be used to more accurately mount the wheel with the collet.

6. Choose the type of pin sleeve that best fits the lugholes in the wheel. 3/4 inch diameter conical pin sleeves, 106-145-2, will fit smaller lugholes.
 1-inch diameter conical pin sleeves, 106-143-2, will fit larger lugholes.
 7/8-inch diameter spherical pin sleeves, 106-144-2, will fit lugholes of many German autos.

**NOTICE**

If the installation of pin sleeve is difficult or not secure, clean inside of pin sleeves and pin assemblies, then apply light machine oil to mating surfaces.

7. Push the pin sleeve to the end of pin assemblies

Use Adjustable Flange Plate to Mount Wheel to Balancer as follows:

1. Determine the cone (or collet) that best fits the center bore of the wheel to be balanced. Choose the cone the contacts the wheel nearest to the center of the cone.
2. Place the wheel-mounting cone on the spindle against the spring plate.
3. With the wheel on the garage floor, adjust the flange plate to match pins with the lug pattern of the wheel. Adjust the diameter of the pin pattern on the flange plate by turning the guide plate against the hub plate.
4. Tighten the thumbscrew located on the guide side of the flange plate to lock the guide plate and pin positions.

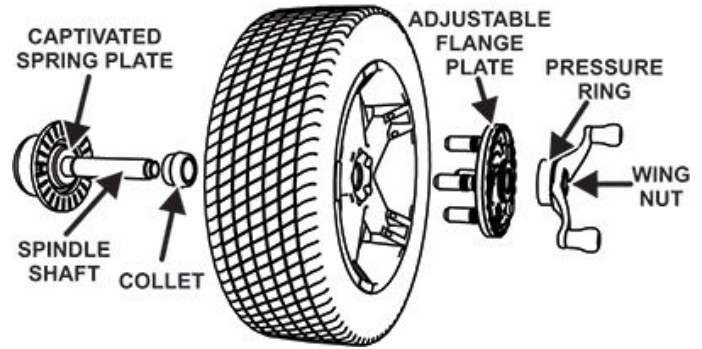

WARNING

The pin pattern on the flange plate must be adjusted to the diameter of the lug pattern of the wheel, prior to mounting the flange plate to the balancer. The pins will NOT self adjust as the wing nut is tightened. If the pins are not properly adjusted to the lug pattern, the pin tabs, adjustable flange plate or wheel may be damaged.

5. Mount the wheel with the inner rim facing the balancer and centered on the cone.
6. Mount the adjustable flange plate to spindle with pins matched to lug holes.
7. Install the pressure ring (or clamping cup) and wing nut on the spindle shaft against the adjustable flange plate.
8. Secure the entire assembly by firmly tightening the wing nut.

Disassemble Flange Plate Set-Up as follows:

1. Pull pin sleeves from the end of the pin assemblies.
2. Remove the pin assemblies from the numbered slots by pushing down and rotating each pin a quarter turn. Leave the index pin on the adjustable flange plate.
3. Place pin sleeves and pin assemblies in the storage bin located on side of balancer.



WARNING

An expandable collet should NOT be used with the HDElite due to the amount of force applied by the load roller.

Using the Pressure Ring and Spacers

Pressure Ring

The pressure ring clips on to the wing nut. It is used in lieu of the clamping cup. It may also be used in place of a clamping cup if space is limited between the wheel and the end of the spindle.

The pressure ring should be used to prevent the wing nut from directly contacting an adaptor or a collet.

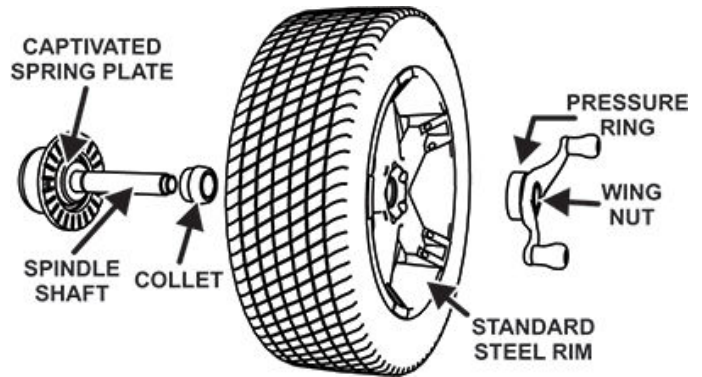

It will act as a bearing to enable higher clamping forces.

Hub Ring Spacers

These spacers are designed to build a larger pocket when using extra large collets. It also provides a location for the centering pins found on some dual wheel configurations.

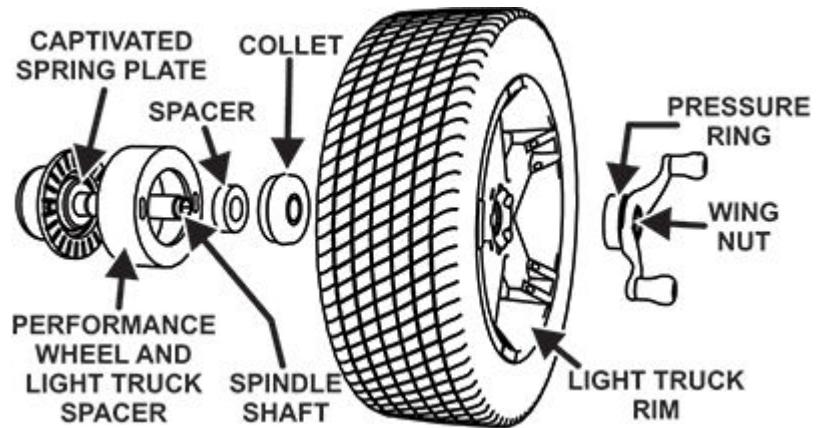

3.4. Wheel Assembly Selection for Saving Spin Data

SAVING SPIN DATA

The HD Elite® automatically tracks the wheel assembly currently being balanced. The balancer assumes that the technician is working “around the vehicle” by beginning at the LEFT FRONT and working around the vehicle in a clockwise fashion. Successive spins are stored as either “before” or “after” data based on the following rules:

- If the weight displays read “OK/OK” or is blank, assume the next complete spin is “before” data.
- If the weight displays read anything other than “OK / OK” or is blank, assume the next complete spin is “after” data.

MEASUREMENT STORAGE

The HD Elite® automatically tracks the wheel assemblies as they are balanced. As the wheel assemblies are balanced, their status can be viewed as they would appear on the vehicle currently being serviced. Select the VirtualView® button to expand the VirtualView® panel. The panel can be further expanded to show detailed information for up to the last eight wheel assemblies balanced.

PRINT SUMMARY

A printout is available that incorporates a detailed image of each wheel assembly with the stored measurements. If a measured value is out of tolerance compared to the recalled specification, the value will be printed in red. From the main balance screen, select “Print” > “Vehicle Summary”. The Vehicle Summary screen will be displayed.

3.5. Balance Modes

SmartWeight Balancing Technology® is a method of reducing forces on a wheel during balancing.

SmartWeight® is not a procedure. Instead, it measures the forces of side-to-side movement and up-and-down shake and computes weight to reduce these forces. This reduces the amount of correction weight used, balancing time required, check spins needed and “weight chasing”.

SmartWeight® saves the shop time and money.

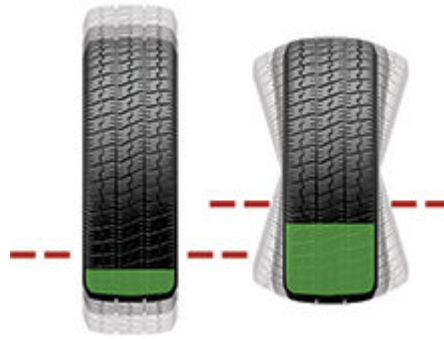

Dynamic Balancing – Traditional Balancing Mode



NOTICE

SmartWeight Balancing Technology® is the default balancing method and is the most recommended way to accurately balance wheel / tire assemblies.

Enter wheel dimensions before selecting dynamic balancing. If SmartWeight® mode is enabled in setup, the balancer will return to SmartWeight® balancing upon dimension entry.

Dynamic balancing will always display two weight planes. It provides a more complete balance than static balancing. Dynamic balancing should be selected whenever possible to minimize vehicle vibration.

Switching from SmartWeight Balancing Technology® to Traditional Dynamic Balancing

At any time, SmartWeight Balancing Technology® can be switched to standard balancing provided that both standard and SmartWeight® balancing modes are enabled in setup.

Selecting the SmartWeight® button to display the SmartWeight® menu buttons.



NOTICE

When changing to traditional dynamic balancing mode, weight amounts as well as weight placement locations change.

Static Balancing – Traditional Balancing Mode



NOTICE

Enter wheel dimensions before selecting dynamic balancing. If SmartWeight® mode is enabled in setup, the balancer will return to SmartWeight® balancing upon dimension entry.

Static balancing provides a less desirable balance than dynamic balancing. Dynamic balancing should be selected whenever possible to minimize vehicle vibration.

Switching from Traditional Dynamic Balancing to Traditional Static Balancing.

In non-SmartWeight® mode, the balancer can be switched from dynamic balancing to static balancing.

Dynamic mode is selected:



Select static mode icon to switch to static mode.



Blinding and Rounding

In non-SmartWeight® mode, the balancer can display either an “actual” or “blinded and rounded” amount of imbalance.

Selecting the magnifying glass icon next to the dynamic or static icons will toggle blinding and rounding on or off.

Dynamic mode, blinding/rounding is disabled:

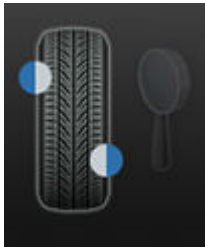

Static mode, blinding/rounding is enabled:



3.6. Motor Drive / Servo-Stop and Spindle-Lok

WHEEL CLAMPING



DANGER

Keep clear of clamping components during shaft rotation.



WARNING

Wheel clamping does not tighten the wing nut! In wheel clamping rotation, torque allowed is minimal. Therefore, the wing nut must still be hand-tightened before balancing.



NOTE

Because of the software limited torque control, you must loosen the wing nut before you remove it.

MOTOR DRIVE / SERVO-STOP

The intelligent DC motor drive on the HD Elite Balancer is able to position and hold the tire assembly in position for weight application, apply different amounts of torque, and control the speed and direction of the spindle.

When the “Start” button is touched with the hood in the raised position, while weights are showing, the motor will automatically rotate the wheel to the next weight plane and hold the assembly in position for weight or mark application. Alternatively, touching the weight amounts will achieve the same results.



SPINDLE-LOK® FEATURE

Depressing the foot pedal will lock the spindle. Locking the spindle will stabilize the wheel for attaching weights at precise locations if automatic weight positioning is disabled, and will allow for tightening and loosening of the wing nut. Do not use the Spindle-Lok® as a brake to stop a spinning wheel.



NOTE

Depressing the foot pedal will cancel Servo-Stop.



WARNING

Using the Spindle-Lok® to stop a spinning wheel may result in personal injury or damage to the balancer.

3.7. Safety Hood Features

Hood Autostart

The balancer can be set to automatically spin the wheel upon hood closure. After a spin, the hood must be raised completely before the balancer will Autostart again. For safety, the balancer will not Autostart in “Calibration,” “Setup,” “Diagnostics,” if no balancing procedure is selected, or if the Inflation Station hose is out of its “home position.”

Auto Hood Feature



WARNING

Keep body parts and items away from the hood while a spin is in progress.

3.8. Balancing Procedures for Specific Weight Types & Placement using TruWeight™

The SmartWeight® HN offers both automatic and manual modes for weight placement.

Automatic Mode



Manual Mode

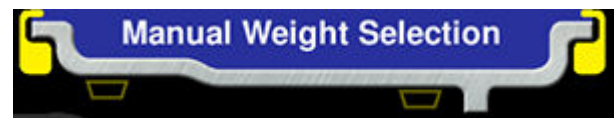

Clip-clip, tape-tape and mixed weight modes are available for both dynamic and static balancing. With these options, correction weights can be placed at an infinite number of locations, based upon the choice of the operator.

Automatic is the default setting, automatically choosing the correct type of weights and locations determined by the placement of the Dataset® arms. TruWeight™ shows the operator exactly how to place the weights on the wheel. Place them exactly as displayed on the screen.

SmartScan™ Dimensions Entry

From the main balance screen, the operator can take wheel dimensions using SmartScan™ dimension entry. This is done automatically by SmartScan's™ inner and outer cameras when lowering the hood and performing a balance spin. Runout, rim dimension, spoke and weight plane location, as well as the wheel weight type (either clip or tape) are calculated automatically by SmartScan™ on every spin.



NOTE

If a wheel weight type other than what is determined by SmartScan™ is desired, users may touch a different weight plane to change weight type.

Incorrect or missing spoke locations do not affect the balancer's ability to properly balance wheels. Rim profile calculations are performed separately from spoke identification. This can be verified by comparing the appearance of the 3D generated profile to the actual wheel. Simply touch the "Enter Spokes" button and enter spoke locations manually to correct spoke identification errors.

Single Weight Placement

Occasionally, regardless of the weight mode, a single tape weight is shown in the middle of the wheel. Place the weight as shown on-screen. The crucial task is to line up the center of the weight with the laser line. The depth of placement does not need to be exact, use features of the rim profile to determine the location.

3.8.1. Balancing Procedure Using Clip-On Weights

Verify the correct clip-on weight type will be used for the wheel that is being balanced.

Verify that the wheel is clean and free of debris. Remove all previous weights.

Mount tire/wheel assembly. Close safety hood

Touch the green "START" button if "Hood Autostart" is disabled.

As the wheel is spinning, the amount(s) of corrective weight(s) needed will be shown on the screen. This time can be used to find and prepare the needed weights.

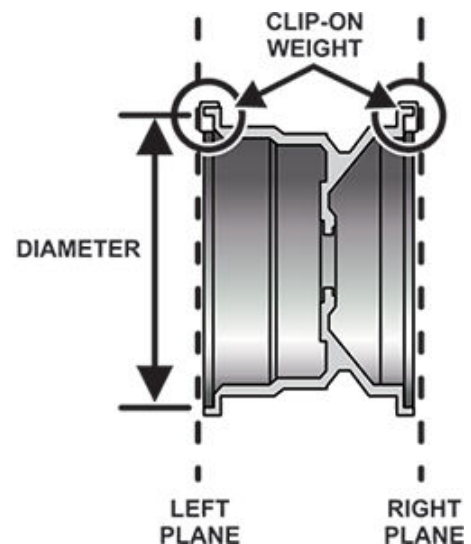

NOTICE

Once weight amounts are shown on the screen, they can be toggled to display either ounces or grams by selecting the "oz" or "g" graphic shown after the weight amount.

After wheel comes to a complete stop, raise the safety hood.



NOTICE

If Auto Hood is enabled, the hood will raise automatically.

The HD Elite® will find the top-dead-center (TDC) for the first weight plane if “Servo-Stop” is enabled. “Servo-Stop” will hold the wheel in the TDC position while the weight is applied.

Attach the weight amount shown on the screen for the selected weight plane to the correct side of the wheel.



TruWeight™ shows the operator exactly how to place the weights on the wheel. Place them exactly as displayed on the screen.



NOTICE

If the optional HammerHead® TDC weight locator is installed, the weight should be applied at the location marked by the laser.

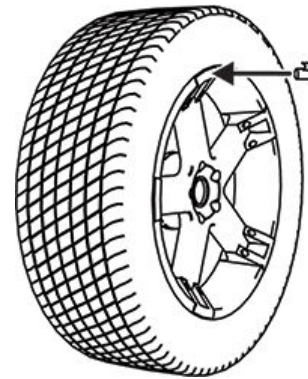

Select the green “START” button with the safety hood in the raised position. The HD Elite® will rotate the wheel to TDC for the next weight plane.

The view of the wheel will also change to the next plane view and the weight amount for the next plane will be displayed in green.



NOTICE

Optionally, selecting the next plane weight amount will rotate the wheel to TDC for the next weight plane.

Attach the weight amount shown on the screen for the selected weight plane to the correct side of the wheel. TruWeight™ shows the operator exactly how to place the weights on the wheel. Place them exactly as displayed on the screen.

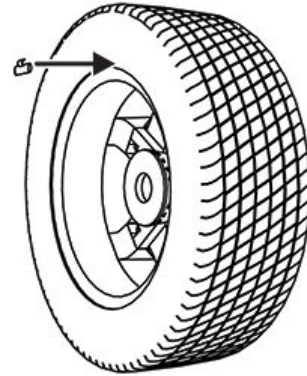

NOTICE

If the optional HammerHead® TCD weight locator is installed, the weight should be applied at the location marked by the laser.

Close the safety hood to perform a check spin.

Left and right weight plane displays should show “OK” after the check spin.

The clip-on weight balancing procedure is complete.



3.8.2. Balancing Procedures Using a Combo of Clip-On & Adhesive (Tape) Weights (Mixed Weights)

Verify that the wheel is clean and free of debris. Remove all previous weights. Mount tire/wheel assembly. Close the hood to perform a balance spin to measure the distance, diameter, runout and rim width dimensions.

As the wheel is spinning, the amount(s) of corrective weight(s) needed will be shown on the screen. This time can be used to find and prepare the needed weights. After wheel comes to a complete stop, raise safety hood.

The HD Elite® will find the top-dead center (TDC) for the first weight plane if “Servo-Stop” is enabled. “Servo-Stop” will hold the wheel in the TDC position while the weight is applied.



Attach the clip-on weight amount shown on the screen for the left weight plane to the inner rim of the wheel.

TruWeight® shows the operator exactly how to place the weights on the wheel. Place them exactly as displayed on the screen.

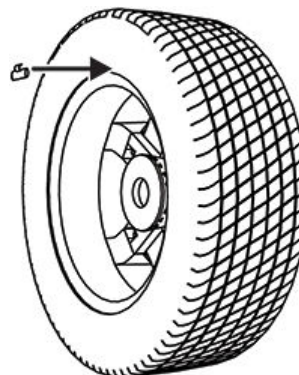

NOTICE

If the optional HammerHead® TDC weight locator is installed, the weight should be applied at the location marked by the laser.

Touch the green "START" button with the safety hood in the raised position.



NOTICE

Optionally, pressing the next plane weight amount will rotate the wheel to the next weight plane.



The HD Elite inner camera quickly locates and marks adhesive weight positioning.

The laser locator automatically displays a vivid line at bottom dead center after a wheel has been spun. The laser turns off when the wheel is spun again.



CAUTION

Caution! Use of controls or adjustments or performance of procedures other than those specified herein may result in hazardous radiation exposure.

With the servo enabled, attach the adhesive weight using the weight amount shown for the right weight plane on the screen.

TruWeight® shows the operator exactly how to place the weights on the wheel. Place them exactly as displayed on the screen. Close the safety hood to perform a check spin.

Left and right weight plane displays should show "OK" after check spin.



MIXED WEIGHTS balancing procedure is complete.

3.8.3. Balancing Procedure Using Adhesive (Tape) Weights

Verify that the wheel is clean and free of debris. Remove all previous weights. Mount tire/wheel assembly.

Close the hood to perform a balance spin. Information is computed automatically.

As the wheel is spinning, the amount(s) of corrective weight(s) needed will be shown on the screen. This time can be used to find and prepare the needed weights.

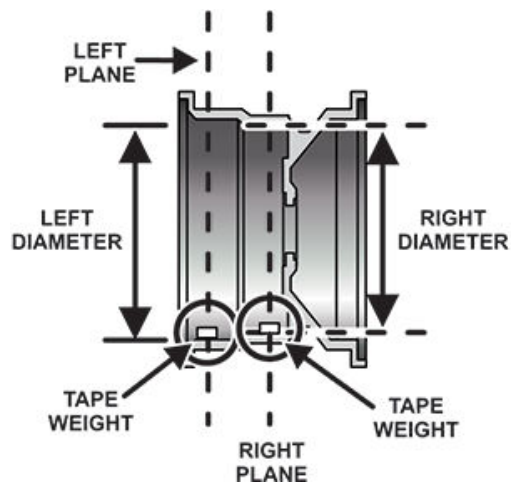



NOTICE

Once weight amounts are shown on the screen, they can be toggled to display either ounces or grams by pressing the “oz” or “g” graphic shown after the weight amount.

After wheel comes to a complete stop, raise the safety hood.



NOTICE

If Auto Hood is enabled, the hood will raise automatically.

The HD Elite® Servo-Activated Laser automatically locates adhesive weight positioning.

The laser weight locator automatically displays a vivid line after a wheel has been spun. The laser turns off when the wheel is spun again.



CAUTION

Use of controls or adjustments or performance of procedures other than those specified herein may result in hazardous radiation exposure.

With the servo enabled, attach the adhesive weight using the weight amount shown for the left weight plane on the screen. TruWeight® shows the operator exactly how to place the weights on the wheel. Place them exactly as displayed on the screen.

Touch the green “START” button with the safety hood in the raised position.



NOTICE

Optionally, pressing the next plane weight amount will rotate the wheel to the next weight plane.



Close the safety hood to perform a check spin.

Left and right weight plane displays should show “OK” after the check spin.

Enable Dragging Feature

The Enable Dragging feature allows the user to drag tape weights to a specific area of the wheel.

Touch the “Measurements” icon on the left side of the screen after a balance spin. Touch the “Enable Dragging” button on the right hand side of the screen. Users can now drag the tape weight(s) as desired.

3.9. Rim Dimension Manual Entry

3.9.1. Rim Dimension Manual Entry - Tape/Tape

In the event of an SmartScan™ failure, balancing can still be performed by using a tape measure to manually input rim dimensions.

Press the dimension button on in the upper left-hand portion of the screen.



Press the Manual Entry button in the upper right-hand portion of the screen.

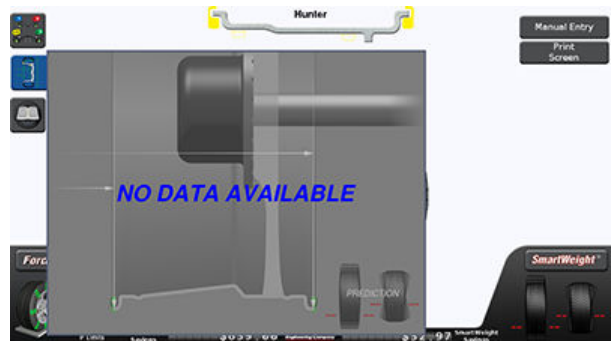

Use a tape measure to measure the lengths called out on-screen. Touch each box and enter the appropriate measured dimensions. When finished, press OK to end manual dimension entry.

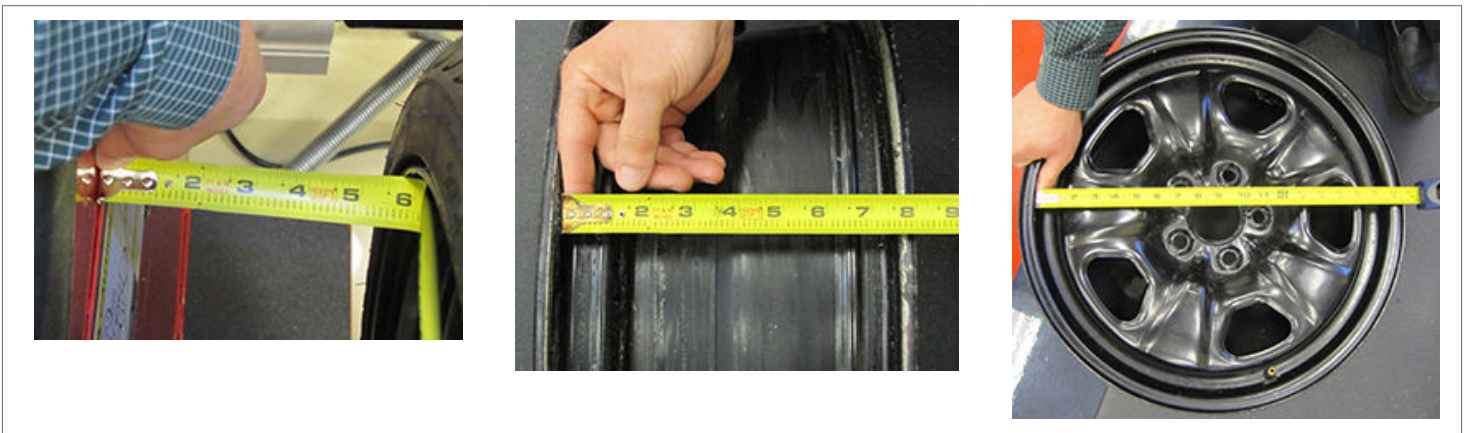
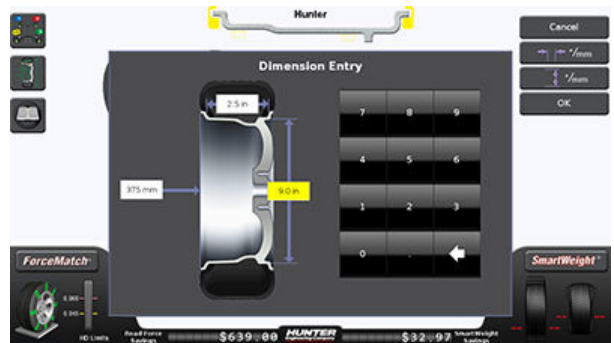

3.9.2. Rim Dimension Manual Entry - Clip/Clip

In the event of an SmartScan™ failure, balancing can still be performed by using a tape measure to manually input rim dimensions.

Press the dimension button on in the upper left-hand portion of the screen.



Press the Manual Entry button in the upper right-hand portion of the screen.

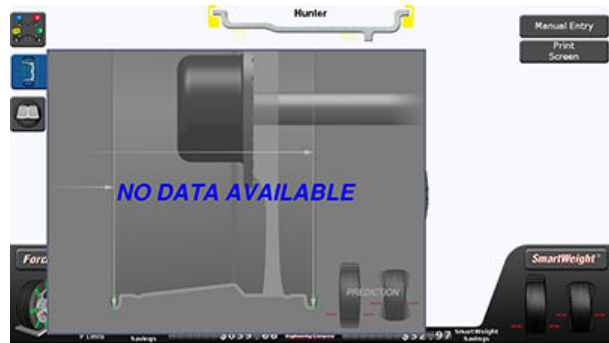

Use a tape measure to measure the lengths called out on-screen.

Touch each box and enter the appropriate measured dimensions. When finished, press OK to end manual dimension entry.

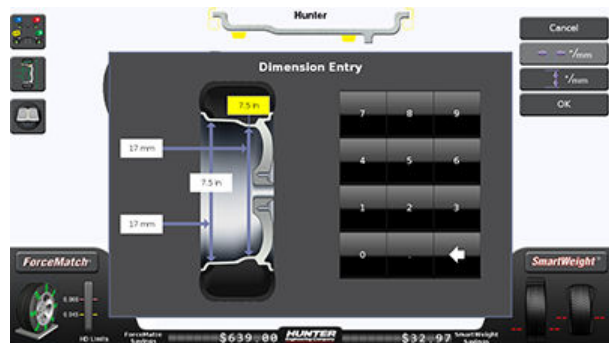

3.9.3. Blinding and Rounding

In non-SmartWeight mode the balancer can display either an “actual” or “blinded and rounded” amount of imbalance.

“Blind” is a tolerance or amount of imbalance required before an imbalance amount is displayed. “Round” allows the balancer to display weight imbalance to a desired increment. The blind and round values can be changed in the “Setup” procedure.

While in the “Balance” primary screen, blind and rounding may be disabled by touching the screen to highlight the magnifying glass. The actual amounts of imbalance for the selected mode will be displayed when “Blind and Rounding” are disabled as shown below.

Dynamic mode, blinding/rounding is disabled:

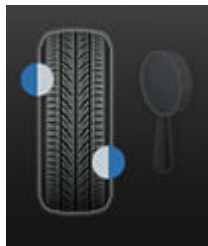

Static mode, blinding/rounding is enabled:



3.9.4. Tape Weight Menu & Split Spoke Feature

Tape Weight Menu

By touching a weight on the wheel, such as the strips of weight shown below, a weight style menu will appear. This offers the ability to change to another style of tape weight and/or split the weight. This can improve balancing accuracy.

Split Weight®

The split weight® software fans the weight on selected plane into two smaller weights. Repeated touches of “Split the Weight” will provide alternate choices where the weights fan further apart but become larger to accommodate the correction needed.

Correcting Large Imbalances

Split Weight® can also be used to apply three weights when needed.

Split Spoke® Feature

When in either mixed weight or adhesive weight modes, (dynamic or static), correction weights can be hidden behind the spokes of a wheel.

Split Spoke® can be turned on as used as the default based on the wheel scan. If the Split Spoke® feature of hiding weights behind spokes is to be used, touch “**Spokes**” > “**Enter Spokes**”. Follow the on screen instructions. Move to the next spoke and repeat. 2 spoke locations are be entered. Continue the balance procedure as normal.



NOTICE

When SmartWeight® is enabled in conjunction with wheel spoke entry, the “SmartSpoke®” weight locator feature can in many instances allow the use of weight at only one spoke when it would have required two using conventional spoke mode balancing.

3.10. Patch Balance® Mode



NOTE

There are 2 methods to enter Patch Balance® Mode.

1st is through the Manual Mode

1. Open the Dimension tab, then select "Manual Mode"
2. Select the top area where the "Shop Name" is and a prompt will appear asking if you want to "Enter patch balance mode?"
3. Enter the dimensions, then select "OK".

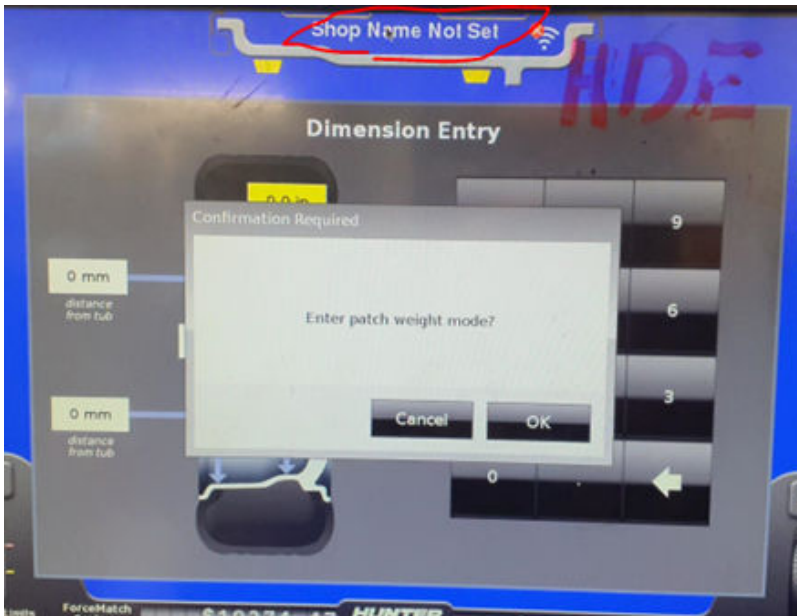

4. Next, lower the hood to spin

2nd is through the vision system.

1. Spin data is required. If there's no spin data, then perform a spin first.
2. Then select the top area where the "Shop Name" is and a prompt will appear asking if you want to "Enter patch balance mode?"

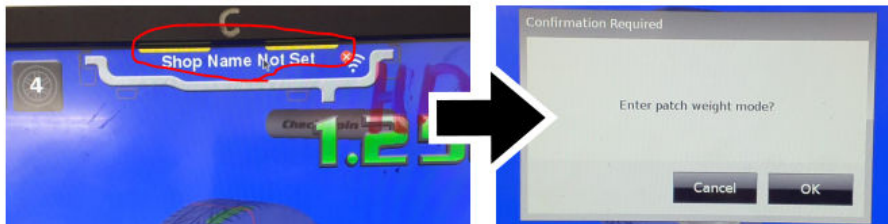

- a. If you perform a non-loaded spin the "Assembly Diameter Entry" screen will appear. Enter data

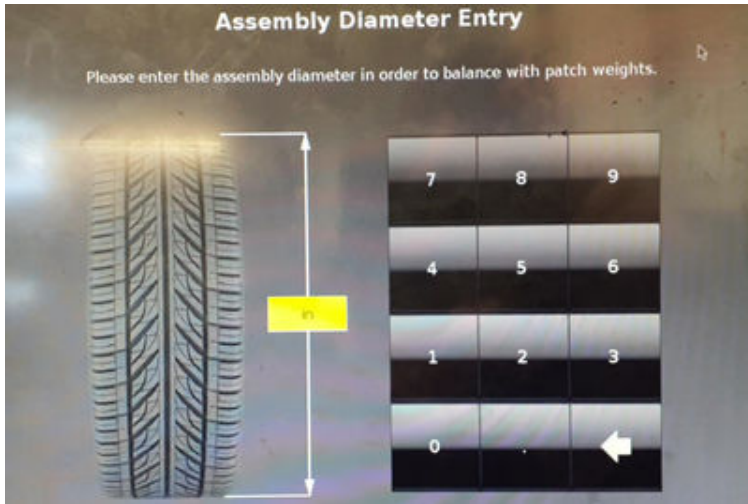

b. Select "Ok" and continue

3.11. Optional HammerHead TDC Laser Clip-On Weight Locator

The balancer will find the TDC for the left or right weight plane if "Servo-Stop" is enabled. "Servo-Stop" will hold the wheel in the TDC position while the servo-activated laser automatically locates TDC to aid in fast clip-on weight positioning.

The HammerHead® TDC Laser System automatically displays a vivid line at top dead center after a wheel has been spun. The laser turns "off" when the wheel is spun again.



CAUTION

Use of controls or adjustments or performance of procedures other than those specified herein may result in hazardous radiation exposure.

This Laser Product is designated as Class 2M during all procedures of operation.



WARNING

Never look directly into the laser. Doing so may cause serious injury.

Table 3. Operation accessible radiation fields

Wavelength:	635-660nm
Laser Power for Classification:	< 1mW via 7mm aperture
Beam Diameter:	< 5mm at aperture
Divergence:	< 1.5mrad x < 2rad
Transverse Beam Mode:	TEM00

Specific Precautions / HammerHead® TDC Laser System



DANGER

Laser Light: DO NOT STARE INTO BEAM. Class 2M Laser Product. 635nm <1mW CW. Classified Per IEC 60825-1, Ed 1.2, 2001-08

Complies with FDA performance standards for laser products except for deviations pursuant to Laser Notice No. 50, dated July 26, 2001.



WARNING

Use of controls, adjustments, or performance of procedures other than those specified herein may result in hazardous radiation exposure. This Laser Product is designated as Class 2M during all procedures of operation.

Do not stare into the beam or view directly with optical instruments. Doing so may cause serious injury.

Do not intentional use a reflective device to enhance or re-direct the laser. Do not operate the laser if the cover or seal is damaged.

There is no required maintenance or service to keep the HammerHead™ TDC Laser System in compliance. The laser is not a field serviceable or an adjustable part.

Any necessary repair or maintenance should be done by the factory only. The HammerHead™ TDC Laser System has no field serviceable parts.

The unit should never be opened or modified.

3.12. TPMSpecs™ Feature & Hunter Help

TPMSpecs™ Feature



NOTICE

TPMS specifications can also be found on Hunter Aligners (with WinAlign 11.0 and greater) and online at UnderCarInfo.NET (subscription service).

The TPMSpecs® feature identifies vehicles with tire pressure monitoring systems. It also provides in depth information regarding the service of TPMS.

- TPMS Type
- Sensor Type
- Reset Required on Tire Rotation or Replacement
- Reset Tool Requirement
- Required Tools
- Reset Procedure
- TPMS Hints
- Information / Disclaimers

TPMSpecs® may be accessed in two ways

Option 1:

From the Main Balance screen, scan a VINbarcode. TPMS information for the vehicle scanned will be automatically retrieved and displayed.

Option 2:

From the main balance screen, touch the "Tools" > "TPMS" buttons.

The main TPMSpecs® screen is displayed. Select the make, model and specifics of the vehicle being serviced.

The “AT A GLANCE” overview starts each vehicle TPMS specification. The first image shows the type of TPMS sensor on the vehicle. The following three images show the requirements for servicing the wheel: process, scan tool and OEM scanner. The red border, yellow border or grayed appearance of the image denotes the requirement as required, optional or not required. Red and white striped border indicates the requirement is possibly required; refer to the explanation below the images.

Scroll up or down by dragging the scroll bar, or touching the “up” and “down” arrows on the right side of the screen.

Touch the “Home” button to return to the main TPMSpecs® Menu. Touch the “arrows” to navigate backward or forward. Touch the “print” button to print the current page. Touch “X” to return to the balancer screen.

Hunter Help - Video Player

The Video Player feature provides tips and procedures for using the HD Elite®. To access the Video Player:

From the main balance screen, touch the “Help” > “Launch Video Player” buttons.

The main video menu screen is displayed.

Select a topic from the menu to view the video.

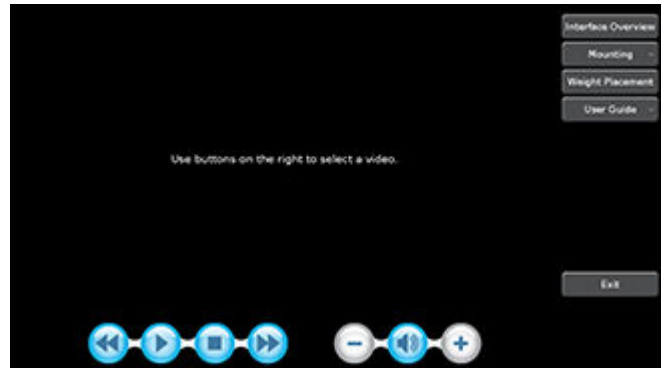

NOTICE

The video screens may change as new content is added.

The selected video will begin playing.

Go back in the video by touching the “back” button. Play the video by touching the “play” button. Stop the video by touching the “stop” button. Go forward in the video by touching the “forward” button. Decrease the video volume by touching the “-” button. Mute the video volume by touching the “mute” button. Increase the video volume by touching the “+” button.

Exit the video player by touching the “Exit” button.

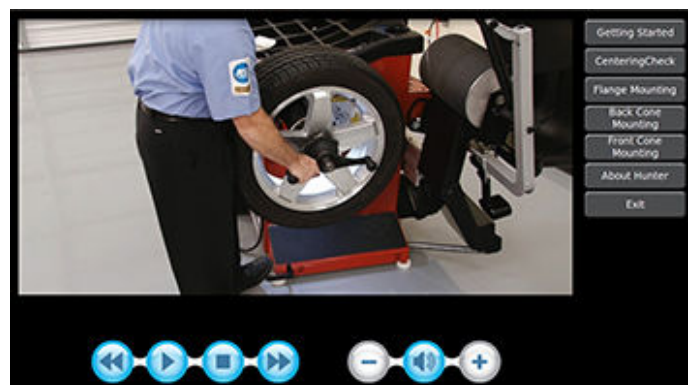

Launch Help

The Hunter Help feature provides tips and procedures for Hunter balancers and tire changers. It also provides a Rolling Smooth Sample Quiz. Additional content will be added to the Hunter Help files and can be updated as it becomes available. To access Hunter Help:

From the main balance screen, touch the “Help” > “Launch Help” buttons.

The Main Menu of Hunter Help is displayed. Select the item to view by touching the selection.



NOTICE

The help screens may change as new content is added.

Some items have sub-menus that will display help on a specific topic. Touch to view the selected topic. Detailed help on specific topics can also be printed. Select "Print" to print the page currently being viewed.

Scroll up or down by dragging the scroll bar, or touching the "up" and "down" arrows on the right side of the screen. Touch the "Home" button to return to the main Hunter Help Menu.

Touch the "arrows" to navigate backward or forward. Touch the "print" button to print the current page. Touch "X" to return to the balancer screen.

4. SmartWeight® Balancing

4.1. SmartWeight Balancing Technology

SmartWeight® Balancing Technology is not a procedure. Rather, it is a technology that measures the forces of couple side-to-side shimmy and static up-and-down shake and computes the correction weight required to reduce these forces. This reduces the amount of weight used, reduces time, reduces check spins, “chasing weights”, and saves shop time and money.

SmartWeight® Balancing Technology can reduce the number of steps in the balancing process. Not only does SmartWeight® Balancing Technology give the customer a better riding vehicle, it also helps the environment by using less corrective weight.

Static and non-rounding modes are eliminated to simplify operation. Always enter at least two weight positions during wheel measurement in SmartWeight® balancing mode. All other functions are identical to the traditional balancing method.

Static and Dynamic Imbalance Sensitivity

As a general rule of thumb, to achieve the best balance on an average sized tire and wheel assembly Residual static imbalance should be less than 1/4 ounce (7 grams).

- Residual couple imbalance should be less than 3/4 ounce (21 grams).
- Residual couple imbalance is preferred over remaining static imbalance.
- It takes much more residual couple imbalance weight to cause a vibration than the same amount of static imbalance correction weight.
- The larger the diameter used for weight placement, the smaller the amount of correction weight is required for static correction.
- The wider the distance between the two weight placement locations, the smaller the amount of correction weight is required for couple correction.
- If static balance is the only option, always verify that the remaining couple residual imbalance is within acceptable tolerance. This can only be verified using SmartWeight® balancing.



NOTICE

SmartWeight® balancing performs this check automatically.

4.2. SmartWeight® Balancing Technology Dynamic Weight Planes

SmartWeight® requires the operator to enter at least two weight planes. This balancing method will automatically determine if one or both weight planes require a weight to be added. This eliminates “blinded” static single plane balancing, which alone may not be sufficient to solve couple vibration issues. The HD Elite® balancer offers two primary ways to balance tires:

SmartWeight® Balancing Technology



Traditional balancing technology



Both of these methods can balance tires dynamically. The main difference being that SmartWeight® will reduce the amount of corrective weight in a basic wheel balancing situation and automatically optimize static force reduction and single plane weight placement.

4.3. Using SmartWeight® Balancing Technology

The SmartWeight® balancing forces display varies greatly from the standard balancing display. SmartWeight® tire graphs independently display the static and couple forces within a tire/wheel assembly. A single plane (static) mode and non-round off modes are no longer necessary.

The traditional “static” and “dynamic” modes are eliminated. The traditional non-round off mode is eliminated. These modes are no longer necessary with SmartWeight® balancing.

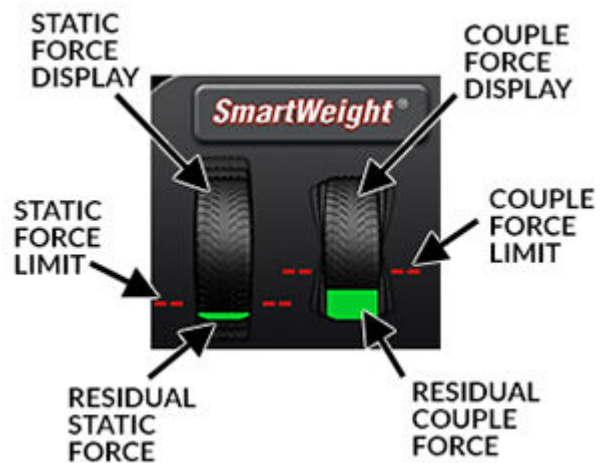

The red-dotted line represents the acceptable amount of force the tire and wheel assembly can have that will not result in a ride problem. Any forces below that line will be shown in green. Any forces that are above that level will be shown in red and indicate an excessive amount of force.

Install a tire/wheel assembly as normal. Rim measurements are not required to determine if the balance forces are exceeded. Lower the hood and spin.



Prior to balance spin, the tire graphs will display no color. The SmartWeight® balance force graphs will display red for excessive forces and green for acceptable amounts of force.



If the SmartWeight® balancing procedure requires correction weights, wheel dimensions will be required. Close the hood and perform a spin.

After the spin is complete, the screen will display the amount and location of corrective weight necessary.



Install the weights as indicated on the screen using the TruWeight® feature. Lower the hood to re-spin and check the balance.

The balancer displays “OK,” indicating that the force levels are reduced to within the acceptable tolerances.



4.4. Switching from SmartWeight® Balancing to Traditional Dynamic Balancing

At any time, SmartWeight® Balancing Technology can be switched to standard balancing provided that both standard and SmartWeight® balancing modes are enabled in setup. Touch the SmartWeight® button to display the SmartWeight® menu buttons.



NOTICE

SmartWeight® Balancing Technology is the default balancing method and is the most recommended way to accurately balance wheel / tire assemblies.



Touch the Disable SmartWeight® button. The balancer is now in traditional dynamic balancing mode.



NOTICE

When changing to traditional dynamic balancing mode, weight amounts as well as weight placement locations change.



4.5. Switching from Traditional Dynamic Balancing to Traditional Static Balancing

In non-SmartWeight® mode, the balancer can be switched from dynamic balancing to static balancing.

Dynamic mode is selected:

Touch the **static mode** icon for static mode balancing.



Blinding and Rounding

In non-SmartWeight® mode, the balancer can display either an “actual” or “blinded and rounded” amount of imbalance. Touching the magnifying glass icon next to the dynamic or static icons will toggle blinding and rounding on or off.

Dynamic mode, blinding/rounding is disabled:

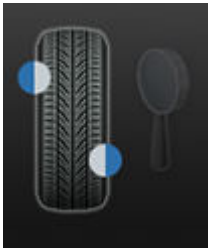

Static mode, blinding/rounding is enabled:



Enable Performance Mode

In SmartWeight® mode, the balancer can be switched to performance mode.

Touch the Enable Performance Mode button.

Table 4. Show Savings

Touch the Show Savings button. The SmartWeight® Savings screen will be displayed.

Touch the Show Details button to view details of SmartWeight® savings. The Weight Savings screen will be displayed.

Touch the Investment Return button. The SmartWeight® and ForceMatch® Investment Return screen will be displayed.

SmartWeight Savings (EXAMPLE DATA)			
Lifetime Savings			
Material Savings		Labor Savings	
Ounces	43992.8	Minutes	8044.5
Rounds	2730.7	Hours	134.1
Boxes (mixed)	1264.8		
Savings	\$132	Savings	\$0
Total		\$132	
Material Savings per Spin		Labor Savings per Spin	
Ounces	0.78	Seconds	8.6
Savings	\$0.23	Savings	\$0.00

Weight Savings (EXAMPLE DATA)										
Clip-Op	Spins	44014	15719	1718	22021	221	2415	Total		
Non-SmartWt	Material	43992.8	43992.8	43992.8	43992.8	43992.8	43992.8	43992.8	43992.8	43992.8
SmartWt	Material	43992.8	43992.8	43992.8	43992.8	43992.8	43992.8	43992.8	43992.8	43992.8
Savings	Material	0	0	0	0	0	0	0	0	0
1 wt req'd		0%	0%	0%	0%	0%	0%	0%	0%	0%
No wt req'd		0%	0%	0%	0%	0%	0%	0%	0%	0%
Clip-Op	Spins	44014	15719	1718	22021	221	2415	Total		
Non-SmartWt	Material	43992.8	43992.8	43992.8	43992.8	43992.8	43992.8	43992.8	43992.8	43992.8
SmartWt	Material	43992.8	43992.8	43992.8	43992.8	43992.8	43992.8	43992.8	43992.8	43992.8
Savings	Material	0	0	0	0	0	0	0	0	0
1 wt req'd		0%	0%	0%	0%	0%	0%	0%	0%	0%
No wt req'd		0%	0%	0%	0%	0%	0%	0%	0%	0%
Type-Op	Spins	80	15719	1718	15899	1589	1589	15892		
Non-SmartWt	Material	43992.8	43992.8	43992.8	43992.8	43992.8	43992.8	43992.8	43992.8	43992.8
SmartWt	Material	43992.8	43992.8	43992.8	43992.8	43992.8	43992.8	43992.8	43992.8	43992.8
Savings	Material	0	0	0	0	0	0	0	0	0
1 wt req'd		0%	0%	0%	0%	0%	0%	0%	0%	0%
No wt req'd		0%	0%	0%	0%	0%	0%	0%	0%	0%

Investment Return	
Road Force and SmartWeight Savings will pay for this balancer.	
Years Remaining for Complete Payback (est.)	1.5
Road Force and SmartWeight Savings Payback To Date (%)	100%

5. ForceMatching Measurement® Procedures

5.1. Load Roller Operation

The load roller runs parallel to the tire and applies a perpendicular load on the assembly to take information required for the HD Elite Measurement® system. The amount of force placed on the tire is dependent upon the tire's diameter and stiffness. The load roller will not overload the tire.



WARNING

Do not use the load roller on assemblies with studded tires.



NOTICE

It is important that the air pressure of the tire is set to specifications prior to using the HD Elite Measurement® system. Incorrect tire pressure will affect the results. If the HD® Elite is equipped with the Inflation Station feature, the tire can be easily set to the specified air pressure.

The load roller can be enabled and disabled by touching the load roller on the screen.

When the load roller is enabled, the screen will display the load roller with enabled settings.



When the load roller is disabled, a red "X" appears on the load roller.



The load roller can also be enabled and disabled by touching the ForceMatch® button then touching the "Toggle Roller" button.

5.2. Forcematching®

Forcematching® is a method of aligning the stiffest spot of the radial tire road force first harmonic (once-per-revolution component) with the average low point of the radial rim runout first harmonic to decrease vibration in the wheel assembly. This type of match mounting has been done with expensive equipment by the tire/wheel manufacturers and OEMs for years to provide the smooth ride associated with a new vehicle. The HD Elite Balancer provides "Forcematching®" at a service level.

When the HD Elite performs a spin with the load roller enabled, it measures the road force of the wheel assembly. ForceMatch® is enabled on every Road Force® spin.

i NOTICE
It is important that the air pressure of the tire is set to specifications prior to using the Road Force Measurement® system. Incorrect tire pressure will affect the results.

Press ForceMatch® in the RoadForce menu and after the assembly has been spun, the ForceMatch data will display on screen.

The upper left corner of the screen displays Road Force® and runout data. A 3D display of the assembly is shown, with corresponding “chalk marks” on both the tire and rim.

Matching the chalk marks will produce the minimum available Road Force® in the assembly

ForceMatch® - Display of Data

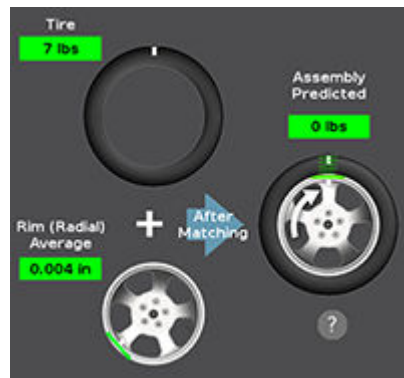

Buttons on the right allow the operator to return to the main balance screen, view details and plots, and change the data being viewed.

Touching “Show After ForceMatching” will change the 3D scene (matching up the chalk marks and showing the resulting Road Force® change in the color spectrum on the tire) as well as show the predicted resultant assembly force and diagnosis (upper left data).

Forcematching® - No Runout

If the operator accesses Forcematching® without the required data having been measured, the screen will prompt the operator. A 180 match will need to be done if this happens.



Forcematching® - Show After Prediction

Touching the “Show After ForceMatching” button will change the 3D scene (matching up the chalk marks and showing the resulting Road Force® change in the color spectrum on the tire) as well as show the predicted resultant assembly force and diagnosis (upper left data).



ForceMatch® Procedures

To correct road force by using ForceMatch®: Rotate the tire Road Force® high spot on the wheel to TDC, or with the hood in the raised position and the servo enabled, touch “START.” Mark the tire with a piece of chalk or a marker at TDC.

Rotate the rim low spot on the wheel to TDC, or with the hood in the raised position and the servo enabled, touch “START.” Mark the rim with a piece of chalk or a marker at TDC.

Use a tire changer and align the tire and rim marks to one another. Refer to the operation instructions for the tire changer in your shop.



NOTICE

If the wheel assembly can be corrected by ForceMatching®, the results can be viewed prior to removing the assembly from the balancer by touching “Show After Forcematching”. If the wheel assembly cannot be corrected by Forcematching®, the diagnosis box will display “Forcematching will not bring assembly within limits” and may suggest component replacement.

Touching the “?” button will display detailed information about the procedure

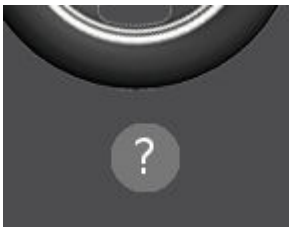

5.2.1. Match Codes

Match codes can be used to obtain optimal ForceMatch® results between multiple tire and rim assemblies. They are especially helpful when high ForceMatch® values are encountered. The former Hunter MatchMaker® feature used a similar system.

When a tire and rim assembly are balanced using ForceMatch®, a number (match code) is displayed above the tire.

This is the value of the high spot on the tire. It is an arbitrary number. The below match code is 12.



When the tire and rim assembly is rotated to the low spot on the rim, a number (match code) is displayed above the tire.

This is the value of the low spot on the rim. It is an arbitrary number. The below match code is 4.



Use a tire changer and align the tire and rim marks to one another as performed in the standard ForceMatch® procedure.

By matching the highest tire match code value with the highest rim match code value, the ForceMatch® values can be reduced in a set of two or more tire and rim assemblies.

The diagram shows a set of four tires and rims and the best use of match codes to reduce ForceMatch® values.

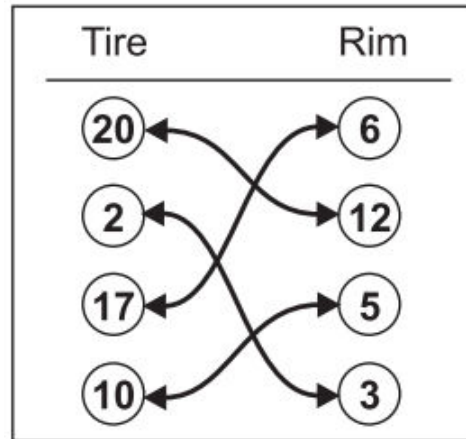

A routine practice of marking the match code values on the tires and rims when using Forcematching® can reduce the overall time needed to perform optimal ForceMatch® results.

180 Matching

180 Matching will minimize ForceMatch® in the tire and wheel assembly. It requires a tire changer, as the tire will be re-positioned about the wheel during the procedure.

The 180 Matching procedure can be launched by touching the "ForceMatch®" > "Procedures" > "180 Matching" button.

The progress bar at the top of the screen indicates to the operator how far along the procedure has progressed. Mount the assembly on the balancer. Set the tire pressure to the vehicle manufacturer's specification. Lower the hood to start the ForceMatch® measurement.



Position the valve stem at 12:00 and touch "Enter Valve Stem".

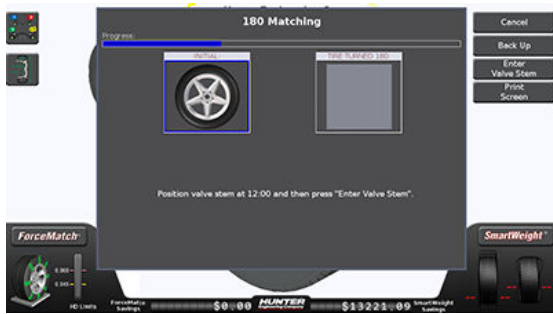

Mark the tire with a piece of chalk or a marker with a "V" opposite the valve stem as indicated. Touch "OK" or tap the foot pedal when completed.



Use a tire changer and rotate the rim 180 degrees relative to the tire, aligning the "V" mark with the valve stem. Mount the assembly on the balancer. Position valve stem at 12:00 and press "Enter Valve Stem".



Lower the hood to start the ForceMatch® measurement.



5.2.2. Encountering Forcematch® Prediction Errors

Below are some reasons why the HD® Elite may not match or quantify the value of the tire or the assembly.

- **Incorrect Mechanical Wheel Mounting on the Shaft:** This can be caused from worn or damaged adaptors, rust or debris on the wheel, shaft, hub, adaptors, or a cone contacting a wheel on an irregular surface. Verify proper mounting by performing a centering check.
- **External Rim Measurement vs. Actual Bead Seat Measurement:** There is a high correlation between external and internal measurement, however the operator must consider each wheel design individually. Some cast or closed-faced wheels cannot be accurately measured externally. The tire must be removed for accurate bead seat runout measurements.
- **Air Pressure Readings Before and After Matching Differ:** The air pressure should remain constant between each measurement. Always inflate tires to the recommended pressure specified by the vehicle manufacturer.
- **Incorrect Tire Bead Seating Procedures:** Tire technology is always changing. Today's vehicles 48 Balancing Procedures require the tire to be designed to tightly adhere to the wheel, preventing slippage between the two components. As a result, incorrect tire bead seating procedures are becoming more of an issue in solving vibration complaints. In many cases, a wheel will display high non-uniformity values because of increased tire bead interference, wheel design, or improper bead seating procedures. If the tire is re-loosened from the wheel and properly lubricated and remounted, the level of non-uniformity may decrease dramatically. On sensitive vehicles, sometimes there is benefit to slightly over-inflating the tire, deflating the air, and then re-inflating to optimize bead seating.
- **Insufficient Use of Tire Mounting Lube During Mounting:** "Lube is God!" Proper lubrication on the tire bead and rim areas including bead seat, hump, balcony, and drop center are vital in achieving proper seating of the tire bead to the wheel assembly. Aggressive acceleration or braking should be avoided for the first 500 miles to prevent tire to wheel slippage.

- **Rim Safety Hump Design 'Hangs Up' Tire Bead During Bead Seating:** Some types of wheels use a square safety hump that may further inhibit uniform tire bead seating. This further underscores the importance of proper lubrication and bead seating procedures.
- **Temporary Flat Spotting:** Flat spotting may occur when the tire is in one position for an extended period of time, such as a parked vehicle, improper storage of the tire, and temperature extremes. Measurements for force and balance will stabilize as soon as the tire is driven for a few miles. This important issue can also affect traditional wheel balancing procedures.
- **Excessive Lateral Runout of Tire and/or Rim:** A tire or wheel with high lateral readings may affect the predicted results of radial force after Forcematching®.

5.2.3. Do's and Don'ts of Road Force Measurement

- Tires may need to be warmed up to remove temporary flat spots prior to testing.
- Tire inflation pressure must meet vehicle manufacturers specifications.
- Verify the wheel is centered.
- Use the approved adaptors for the HD® Elite. Use approved wing nut provided and tighten with two hands to ensure full clamping force.
- The tire/wheel assembly must be free of debris.
- Bare rim runout measurements are required if the wheel design does not permit external measurement of the outer bead seat area.
- Use realistic ForceMatch® measurement limits for the vehicle being tested.
- If chosen limits have been exceeded, never use ForceMatch® measurement alone to replace a tire unless specified by the manufacturer.

5.2.4. ForceMatch® Savings

Savings generated through prevented comebacks using the ForceMatch® roller can also be viewed. Touch the ForceMatch® button.

In the ForceMatch® menu, touch the Show Savings button. The ForceMatch® savings screen will be displayed.

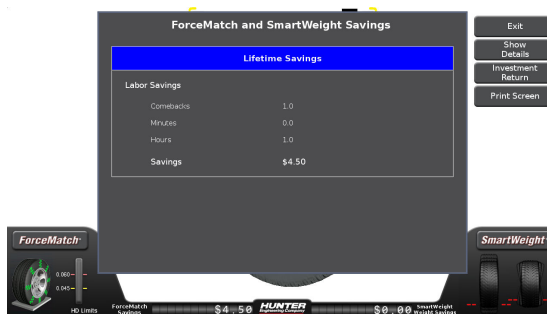

5.3. ForceMatch & SmartWeight Savings

Savings generated through prevented comebacks using the HD Elite® roller can also be viewed.

Touch the ForceMatch® button. In the ForceMatch® menu, touch the Show Savings button.

The ForceMatch and SmartWeight® savings screen will be displayed.

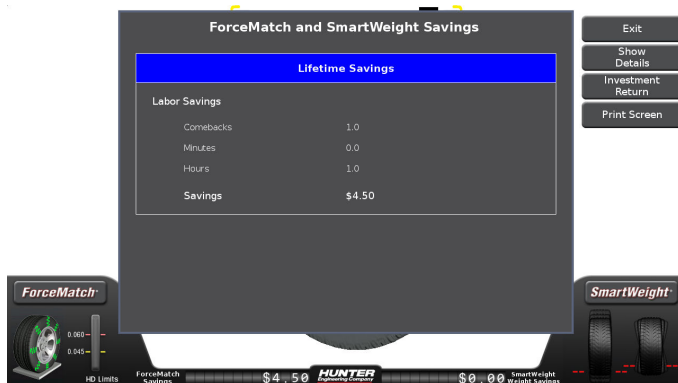

6. Optional Balancer Procedures

6.1. Tools

The Tools button contains equipment information and set up options.

Set Up

The "Set Up" screen contains a list box of balancer set up items. Select the item you wish to set up and follow the on screen prompts.

Maintenance History

From the main balance screen, touch the "Tools" > "Advanced" > "Maintenance History" button.

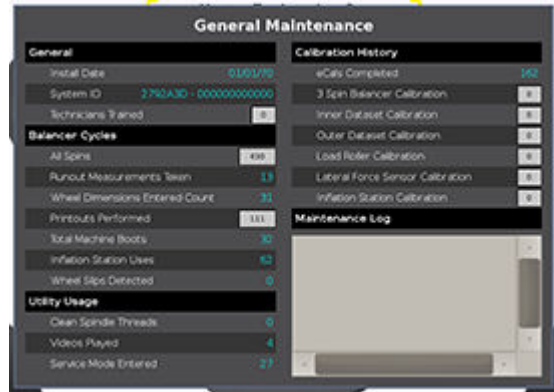

The Maintenance screen displays general balancer history. Pressing any of the grey boxes will show a flyout with more information.

TPMS

From the main balance screen, touch the "Tools" > "TPMS" buttons.

The main TPMSpecs® screen is displayed. Select the make, model and specifics of the vehicle being serviced.



The "AT A GLANCE" overview starts each vehicle TPMS specification. The first image shows the type of TPMS sensor on the vehicle. The following three images show the requirements for servicing the wheel: process, scan tool and OEM scanner.

The red border, yellow border or grayed appearance of the image denotes the requirement as required, optional or not required. Red and white striped border indicates the requirement is possibly required; refer to the explanation below the images.



Scroll up or down by dragging the scroll bar, or touching the “**up**” and “**down**” arrows on the right side of the screen. Touch the “**Home**” button to return to the main TPMSpecs® Menu.

Touch the “**arrows**” to navigate backward or forward. Touch the “**print**” button to print the current page. Touch “**X**” to return to the balancer screen.



Clean Threads

From the main balance screen, touch the “**Tools**” > “**Clean Threads**” buttons. The main Clean Threads Explanation screen is displayed.

Follow the on-screen instructions to clean the spindle threads. After the spindle threads are cleaned, touch the “**Exit**” button to return to the main balance screen.

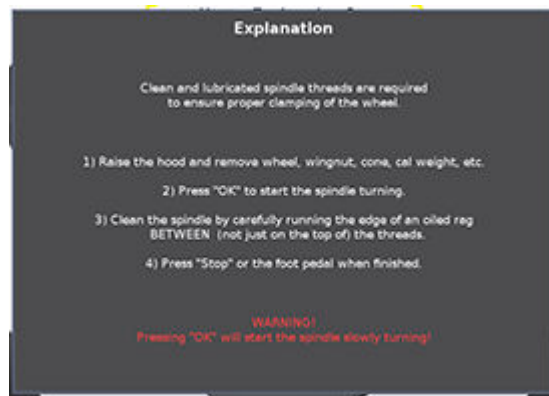

Balance Bare Rim

From the main balance screen, touch the “**Tools**” > “**Balance Bare Rim**” buttons. The balance screen is displayed with a bare rim. During bare rim balancing, the load roller is disabled.

Balance the rim as normal, taking dimensions, applying weights, etc. Touch the “**Balance Rim With Tire**” button to return to standard balancing.

7. Maintenance

7.1. Calibration Procedures

eCal™ Auto-Calibration

The HD® Elite utilizes eCal™ automatic calibration. Once the balancer is calibrated at installation time, no further operator input is required.

Calibration Check

A quick calibration check can be performed on the balancer using a calibration weight. From the main balance screen, touch the **“Tools”** > **“Quick Calibration Check”** buttons.

Screw in the calibration weight and clamp a large cone or collet to the shaft. Lower the hood and press start to begin the check.

Rotate the shaft to the 12:00 position until the yellow dot on the screen turns green to complete the check.



7.2. Cleaning the Console

Safety Instructions

- Please keep the display away from any heat sources such as electric radiators or direct sunlight. Place the display in a stable and well-ventilated place.
- The holes or openings on the display are designed for ventilation. Do not cover or block the ventilation holes or openings with any objects.
- As the display surface is vulnerable to scratches, avoid touching the surface with nail or pen point.
- Do not attempt to repair this product yourself! Improperly disassembly of the product may expose you to danger! If your problem cannot be solved according to the “Troubleshooting” guidelines, contact your regional HP authorized service provider, <https://support.hp.com/us-en>.

Optical Scan Rim Measurement Maintenance or Service

This Laser Product is designated as a class 1 Laser during all procedures of operation. Never look directly into the laser. Doing so may cause serious injury. Do not intentionally use a reflective device to enhance or re-direct the laser. Do not operate the laser if the cover or seal is damaged.

There is no required maintenance or service to keep the Optical Scan Rim Measurement Laser System in compliance. The laser is not a field serviceable part or an adjustable part. Any necessary repair or maintenance should be done by the factory only. The Optical Scan Rim Measurement Laser System has no field serviceable parts. The unit should never be opened or modified.



CAUTION

Use of controls or adjustments or performance of procedures other than those specified herein may result in hazardous radiation exposure.

This Laser Product is designated as Class 2M during all procedures of operation. Do not stare into the beam or view directly with optical instruments. Doing so may cause serious injury.

Do not intentionally use a reflective device to enhance or re-direct the laser. Do not operate the laser if the cover or seal is damaged. There is no required maintenance or service to keep the HammerHead® TDC Laser System in compliance. The laser is not a field serviceable or an adjustable part.

Any necessary repair or maintenance should be done by the factory only. The HammerHead® TDC Laser System has no field serviceable parts.

7.3. Cleaning and Lubricating the Adjustable Flange Plate and Pin

Cleaning and Lubricating the Adjustable Flange Plate



CAUTION

DO NOT pry or hammer stuck pins from adjustable flange plate. The tab at end of pin is made of mild steel that can be deformed by excessive force. Disassemble adjustable flange plate as described below to remove stuck pins and diagnose problem.



NOTICE

If adjust ability of flange plate becomes difficult, clean and lubricate the plate.

1. Use a standard screwdriver to pry retaining spring, 98-405-2, from the backside of adjustable flange plate. Remove the thumbscrew through the side of the flange plate as follows:
Open and then remove the split retaining ring from the thumbscrew, 75-651-1. Unscrew the thumbscrew from the flange plate.
2. Clean grease and grime from hub and guide. Apply light machine oil or light grease to the mating surfaces (including around the slots on the interior surfaces of both the hub and guide).
3. Secure the guide to hub with retaining spring previously removed. Secure the thumbscrew to the flange plate with the split retaining ring.

Pin Assembly Maintenance

Replace tab, 218-185-2, as follows:

Remove pin guide, 135-377-2, from end of the pin assembly and remove the old tab. On one side on the tab the edges are rounded and the other side has sharp edges. Install the new tab with the rounded edges toward the collar, 217-54-2, of the pin assembly.

Match the flat section on the mating surfaces of tab and collar. If a flat washer was located between the tab and pin guide, reassembly the pin assembly with this washer in place. Using Loctite 222 on the threads, secure the tab with the pin guide.

Springs, 98-403-2, must be installed with the concave sides facing each other. When correct, only the outer edges of the springs will contact each other, creating a clam appearance. All the pin assemblies must have the springs installed consistently in this manner.

If the installation and removal of pin sleeves becomes difficult, clean inside of pin sleeves and the pin assemblies, and then apply light machine oil to the mating surfaces. If pin sleeves do not stay on pins, clean excess oil from inside of pin sleeves and the pin assemblies. If the problem persists, replace the two O rings, 124-149-2, on the ends

7.4. Maintenance Schedule



Wheel Balancer - Daily Maintenance

- 1 Clean around and under balancer.** Clear all loose weights from floor.

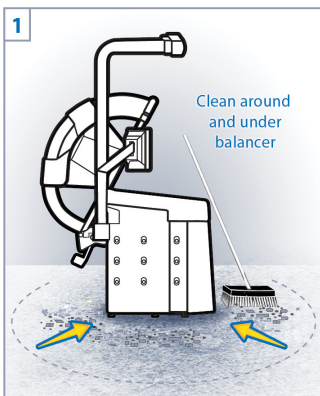

Wheel weights under balancer may cause weight chasing.

- 2 Clean and lube spindle.** Apply 3-in-1 oil to a rag. (*Keep oil from skin.*) Use "Clean Threads" feature to rotate.

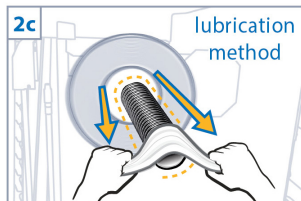
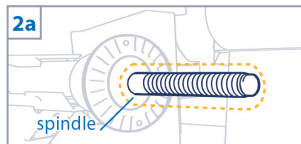

- 3 Clean hub face by hand** with Scotch Brite pad. **Do not lube this surface!**

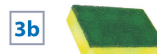

Dry scrub by hand to prevent hub damage. Do not use power tools. **Do NOT use "Clean Threads" to clean hub.**

- 4 Inspect wing-nut and cup.** Gritty bearings, broken knobs and missing handle spacers may cause balance issues.

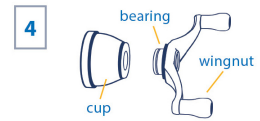

- 5 Perform 3 Spin Balancer Calibration.**

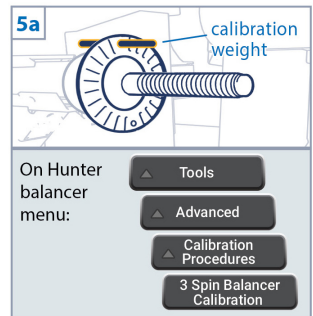

Table 5. Follow schedule to keep balancer performing at its best

Maintenance Schedule	Perform the following Maintenance
Daily	<ul style="list-style-type: none"> • Spindle Maintenance - Keep the spindle shaft assembly and wing nut threads clean and lubricated. Clean the spindle threads by running the edge of a rag between the threads while turning the spindle by hand. Lubricate the shaft with a coating of light lubricant with Teflon® such as Super Lube® by Loctite after cleaning. Do not lubricate the spindle hub face-mounting surface. This could cause slipping between the wheel and the hub face. Keep the hub face-mounting surface clean and dry. • Collet maintenance - Keep the mounting collets clean and lubricated. Lubricate with a coating of light lubricant with Teflon® such as Super Lube® by Loctite. Inspect cones for excess wear, dings, burrs, or other damage that may prohibit proper centering. Do not use cones in any way that is not described in the operation manual. This could cause damage to the mounting cone and not allow for proper mounting of the wheel. • Inspect wingnut and clamp cup for excessive wear or damage. • Cleaning the console - When cleaning the console use the included Armor All Glass wipes to wipe off the display console and cabinet. Do not spray any type of cleaning solution directly onto control panel or LCD resistive touch screen. Do not use shop air to clean the display. Power should be off prior to cleaning the LCD resistive touch screen
Periodically (when balancer chases weight on check spin)	<ul style="list-style-type: none"> • Perform a QuickCal Check to determine if calibration is necessary. This should be performed after balancer has been in operation for at least 10 minutes.
Monthly	<ul style="list-style-type: none"> • Inspect inlet air filter/dryer - clean, replace as necessary
Semi-Annually	<p>Preventative maintenance visit by Hunter Service Representative which will include all the above in addition to the following:</p> <ul style="list-style-type: none"> • Perform audit check (quality report for vibration control system) • Perform full system diagnostics (including air system) • Load roller friction material inspection • Check printer operation • Cone inspection with dial indicator • Check belt tension • Full system calibration



NOTICE

The end user is responsible for replacement of all consumable items such as printer ink cartridges, cleaning wipes, and batteries.



CAUTION

Do not use shop air to clean the LCD resistive touch screen. Shop air could be wet, dirty, or too powerful for the display and can cause problems with the display.

8. Hunter's 3-Year Warranty

January 1, 2021

Hunter Engineering Company warrants new equipment to be free from defects in material and workmanship under normal conditions of use for a period of three (3) years from the date of installation.

The Details

Exceptions to this warranty are listed below:

- Field labor is covered under this warranty for a period of six (6) months.
- ADASLink™ units carry a one (1) year warranty and remain under warranty as long as a subscription is maintained there after.
- DAS 3000 units, including electronic circuit boards, carry a one (1) year warranty.
- Printers carry a one (1) year warranty.
- Normal consumables and wear items are not covered. Exception is batteries, which are warranted for a period of six (6) months.
- Product that has been subject to abuse, misuse, alterations, accident, exposure to the elements, tampering, unreasonable use, or not maintained in a reasonable or necessary manner.
- Replacement parts purchased through the Hunter Service Center and no longer covered by machine warranty are warranted for a period of six (6) months.

How do I submit a claim?

In case of any warranty claim, it will be necessary to contact your local authorized Hunter Service Representative. To have an item considered for warranty, it must be returned to Hunter Engineering Company for inspection and evaluation. This must be done on a freight prepaid basis. If after our inspection the product proves to be defective, and is within the time frame specified, we will repair or replace the item at no additional cost.

This is Hunter Engineering Company's only warranty with respect to new equipment. Hunter Engineering Company disclaims all other warranties to the extent permitted by law. This express warranty and any implied warranties of merchantability and fitness for a particular purpose shall not extend beyond the warranty period. Hunter Engineering Company is not responsible for any incidental or consequential damages, including, but not limited to, loss of business.

Can I transfer my warranty?

We do not authorize any person to assume for us any other liabilities with our products. Any remaining warranty may be transferred to subsequent purchasers by forwarding the purchaser's name, address, phone number and equipment serial number to:

Hunter Engineering Company | Customer Service Department

11250 Hunter Drive, Bridgeton, MO 63044

(800) 448-6848

See our document library at www.Hunter.com for additional details.

Develop skills and knowledge

EXCEL WITH HUNTER TRAINING



Live On-Site Training

All Hunter Training classes are led by ASE-certified instructors and all training material is kept up-to-date through a rigorous curriculum review process.

YouTube Video Tutorials

Product-focused videos explaining features and processes

Hunter University

Self-driven eLearning courses designed for all student levels



hunter.com/training



Hunter Learning Channel



Because of continuing technological advances, specifications, models and options are subject to change without notice.

PowerSlide and WinAlign are registered trademarks of Hunter Engineering Company. The PowerSlide logo is a trademark of Hunter Engineering Company.

HUNTER
Engineering Company
www.hunter.com