

TCX51M

Specialty Mobile Tire Changer

HUNTER
Engineering Company

SITE REQUIREMENTS



TCX51M	
Electrical Supply Requirements	110-120V, 10A, (1200 W) 50/60Hz, 1 Ph NEMA 5-15P plug included
Air Supply Requirements	115-145 psi (8-10 bar)
Base Machine Weight	615 lbs (279 kg)
Width (W)	46 in. (1169 mm)
Height (H)	72 in. (1829 mm)
Depth (D)	48 in. (1219 mm)

KEY SPECIFICATIONS



TCX51M	
Mount / Demount Tool	Winged Polymer Head
Clamping Type	Center w/ Dual Height Positions
Bead Loosening Type	Upper & Lower Rollers
Match Mounting Capable	Yes
Rim Diameter Range	14-26 in.
Maximum Tire Diameter	40 in.
Maximum Wheel Width	13 in.
Rotation Speed	2 Speeds, 7 and 17 RPM clockwise; 7 RPM counterclockwise
Drive Torque	830 ft-lb (1125 N-m)

Shown with optional FastBlast

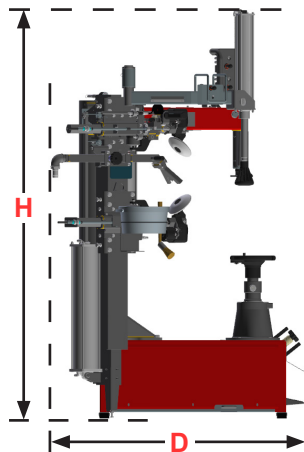
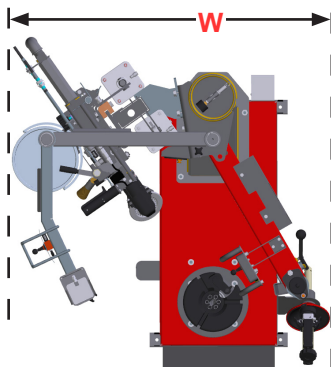

For tire changer information visit:
www.hunter.com/tire-changers

For local contact visit:
www.hunter.com/contact-hunter

For general inquiries visit:
www.hunter.com
or call
800-448-6848