

## SPECIFICATIONS [ ]

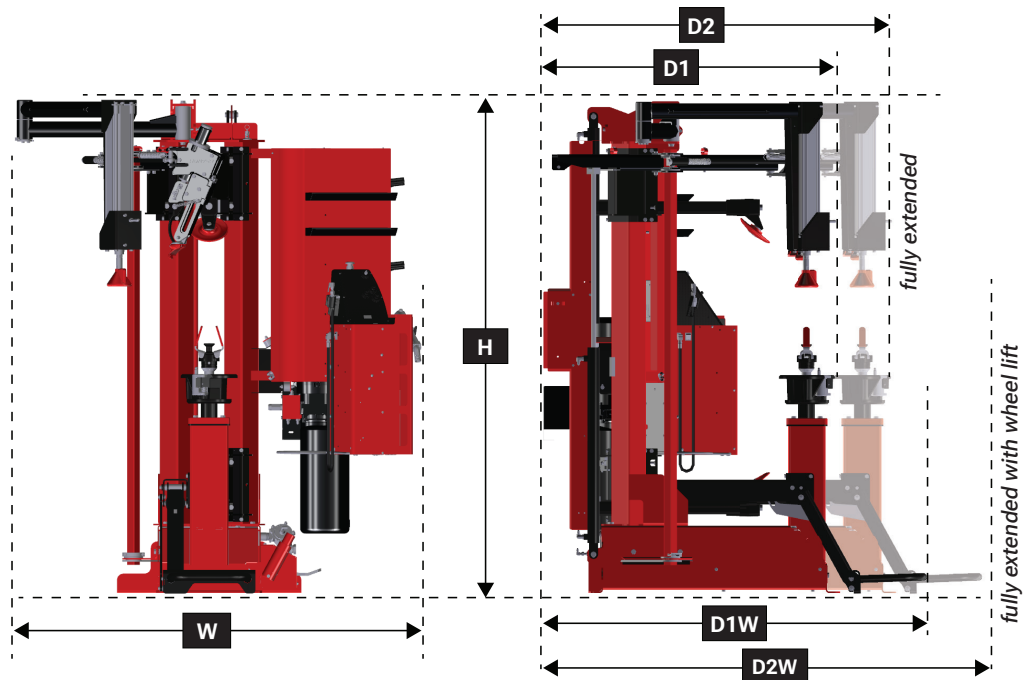

Power Requirements	208-230 VAC, 1 Ph, 60Hz, 14A, NEMA 20 amp plug, L6-20P
Air Supply Requirements	125 ± 25 psi (8.6 ± 1.7 bar)
Weight	TCM: 1065 lbs (483 kg) / TCMW: 1132 lbs (513 kg)
Usable Power Cord Length	~114 in. (2895 mm)
Mount / Demount Tool	Polymer Leverless
Clamping Type	Center w/ Quick Clamp
Bead Loosening Type	Upper Lower Roller
Match Mounting Capable	Yes
Rim Diameter Range	10 in. - 34 in. (254 mm - 863 mm)
Maximum Tire Diameter	50 in. (1,270 mm)
Maximum Wheel Width	19 in. (381 mm)
Maximum Wheel Weight	175 lbs (79 kg)
Drive	Variable up to 17 rpm CW / CCW Torque: 700 ft-lbs (949 Nm)
Width (W)	53 in. (1346 mm)
Height (H)	77 in. (1956 mm)
Depth (D1 / D1W)	46 in. (1168 mm) / 57 in. (1448 mm)
Depth (D2 / D2W)	60 in. (1524 mm) / 71 in. (1803 mm)



For tire changer information visit:  
[hunter.com/tire-changers](http://hunter.com/tire-changers)

For local contact visit:  
[hunter.com/contact](http://hunter.com/contact)

For general inquiries visit:  
[www.hunter.com](http://www.hunter.com) or call **800-448-6848**