

TCA34R

Center-Clamp Tire Changer

HUNTER
Engineering Company

SPECIFICATIONS []



Power Requirements	208-230V, 6A, 60Hz, 1 ph NEMA 20 amp plug, L6-20P
Air Supply Requirements	115 - 175 psi (8-12 bar)
Approximate Air Consumption	4 CFM (110 Liters/Minute)
Weight	1172 lbs (531 kg)
Usable Power Cord Length	~114 in. (2895 mm)
Mount / Demount Tool	Polymer Self Inserting Leverless
Clamping Type	Center w/ Quick Clamp and Cam Plate
Adjustable Clamping Height	Yes
Bead Loosening Type	Upper / Lower Roller
Match Mounting Capable	Yes
Rim Diameter Range	10 in. - 34 in. (254 mm - 863 mm)
Maximum Tire Diameter	65 in. (1,651 mm)
Maximum Wheel Width	19 in. (381 mm)
Wheel Lift Capacity	176 lbs. (80 kg)
Drive	Variable up to 14 rpm CW / 7 rpm CCW Torque: 867 ft-lbs (1175 Nm)
Width (W)	59 in. (1494 mm)
Height (H)	81 in. (2067 mm)
Depth (D1)	65 in. (1651 mm) - chassis retracted
Depth (D2)	79 in. (2015 mm) - chassis retracted

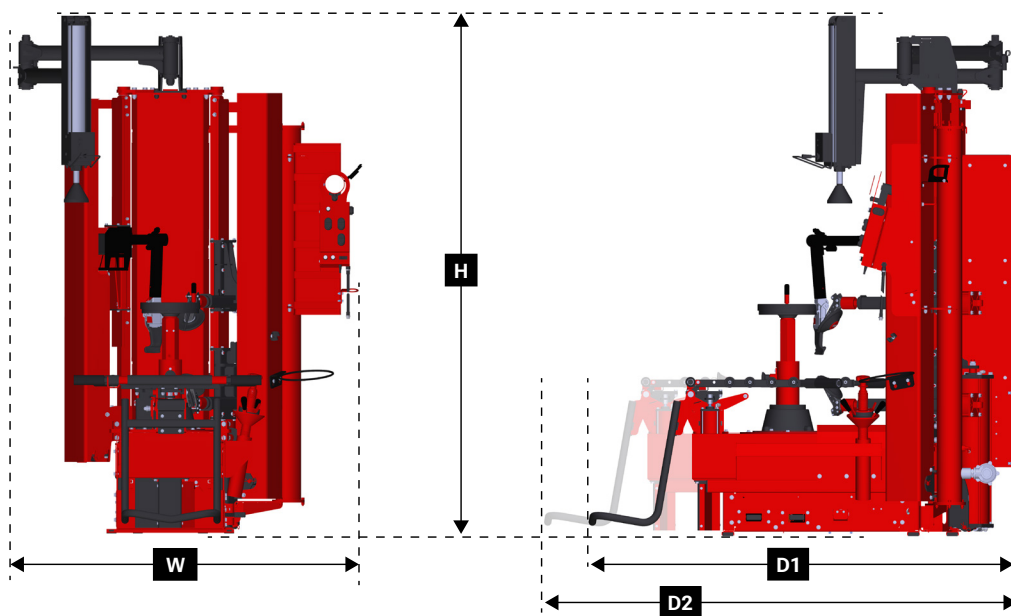

For tire changer information visit:
hunter.com/tire-changers

For local contact visit:
hunter.com/contact

For general inquiries visit:
www.hunter.com or call 800-448-6848

Because of continuing technological advancements, specifications, models and options are subject to change without notice.

Form CS07881-00, 05-24
Supersedes Form Form CS07881-00, 10-22
Copyright ©2024, Hunter Engineering Company