

AUTO34R™

Premium Center Clamp Tire Changer



Simple operation,
superior wheel protection



Three-button
operation



10-34 inch
rim diameters



Secure wheels
with no damage



Adjustable height
clamping



Premium performance, compact package

BROAD CAPABILITIES

Hunter's Auto34R™ tire changer is designed to quickly and easily service the broadest range of assemblies, dramatically reduce opportunities for tire and wheel damage, and keep technicians safe during operation.



Push-button controls

- ✓ Simple, three-button control
- ✓ Easiest operation in its class

Diameter control

- ✓ Telescoping chassis brings the wheel into position
- ✓ Electrical actuation is smooth and precise



Bead press arm

- ✓ Helps mount and demount difficult tires
- ✓ Center-mounted for a tight swing radius for compact footprint



Bead-breaking rollers

- ✓ Gently loosens bead from rim
- ✓ No rim contact
- ✓ Indents automatically

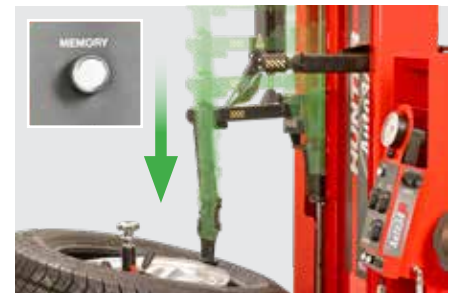

Memory function

- ✓ One button returns mount head to rim height
- ✓ Saves time and mistakes



PATENTED

Leverless tool head

- ✓ Positions bead without levers
- ✓ Prevents damage to tire and rim
- ✓ Adds operator safety



EXCLUSIVE

Wheel support plate

- ✓ Handles wide range of wheels
- ✓ Provides extra gripping force
- ✓ Three adjustable work heights

High-volume blast tank

Slim profile and large capacity to seat truck and SUV tires

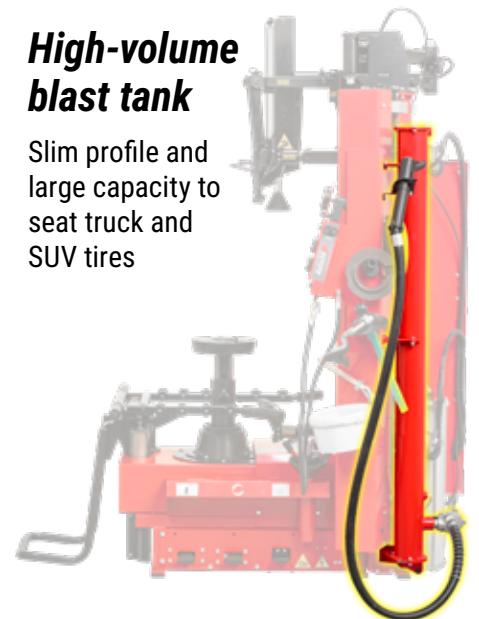

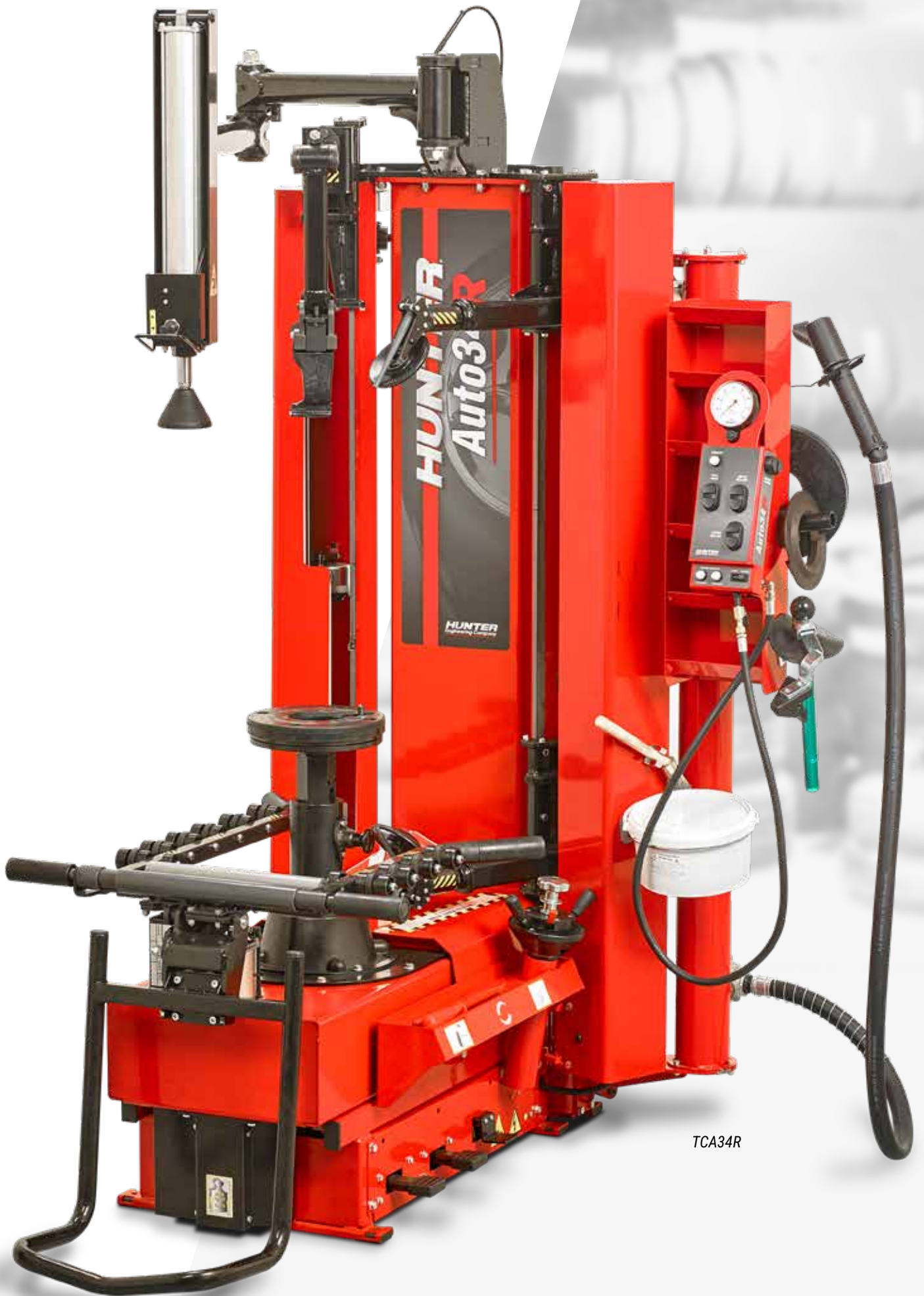

TCA34R

Enhanced features for faster and easier tire service

SMART DESIGN PUTS YOU IN CONTROL

The Auto34R™ tire changer's compact package efficiently delivers premium performance in a small shop space.

Bead loosening roller auto-indention

Sensor detects when roller is under rim flange and automatically indents bead loosening disc.

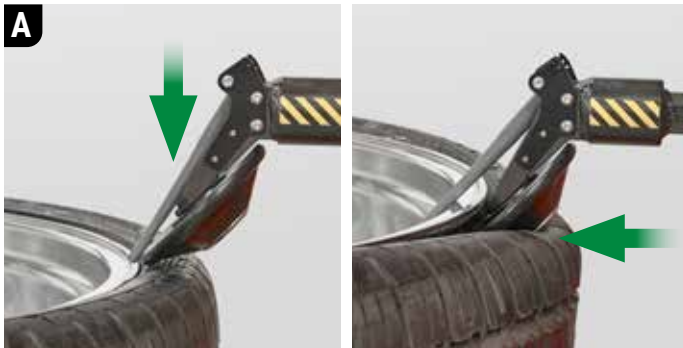

Bead press arm

Assists with mounting and demounting by pushing the tire into the drop center.



Powerful blast inflation

Directs large blast of compressed air exactly where needed to seat the bead.

Motor and drive

- ✓ Variable RPM offers perfect speed and control
- ✓ High-powered electric motor delivers over 850 ft-lbs. of torque

Match-mounting

When used with Hunter's Road Force Elite®, the Auto34R quickly and easily helps eliminate vibration problems balancers alone can't fix.

The Auto34R's bead rollers allow spinning of tire on rim, helping match-mount stiffest point on tire to low spot on rim.





Simple controls

- ✓ Easy-to-operate, intuitive controls
- ✓ Three switches and one foot pedal control virtually all tire changing operations
- ✓ Includes manual controls for advanced or special techniques



Inflation, rotation and wheel lift operations are controlled by three foot pedals.

**STANDARD
Wheel lift**

Easily and safely lift large assemblies with this ergonomic, space-saving design.



Save valuable floor space

- ✓ 15% smaller footprint
- ✓ Reduced swing radius for arms
- ✓ Flat back eliminates bulky cables
- ✓ High-volume vertical blast tank conserves space

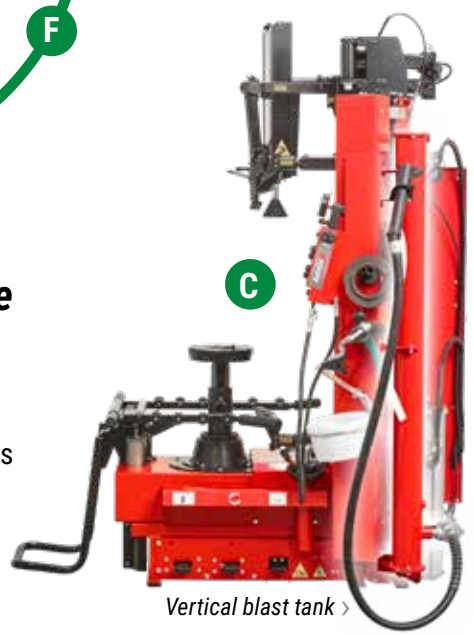

Vertical blast tank >

Make wheel servicing safer and easier

PRECISE, DYNAMIC, AND VERSATILE

The Auto34R™ tire changer is equipped to handle virtually all common tire and wheel combinations while protecting the technician and assembly without sacrificing performance.

Precise diameter adjustment

- ✓ Electric actuator movement is smooth and precise
- ✓ Integrated cams keep rollers and toolhead at the optimal angle for all wheels
- ✓ Reduces mounting forces with perfect alignment of head and rim
- ✓ Adjusts for 10" to 34" wheels at the press of a button

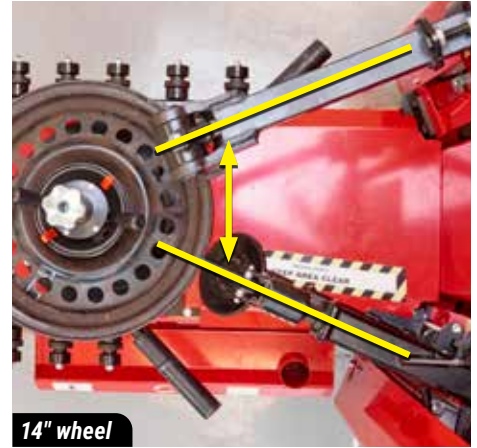
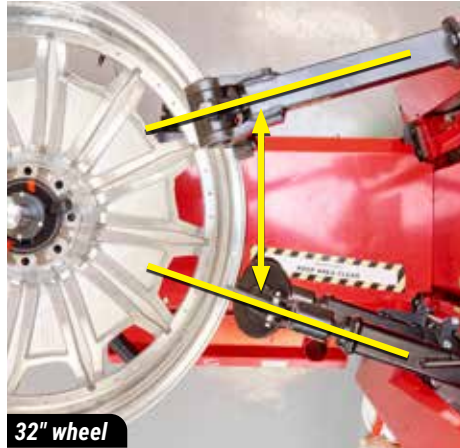

SEE IT IN ACTION
Scan QR code or visit
www.hunter.com/auto34r

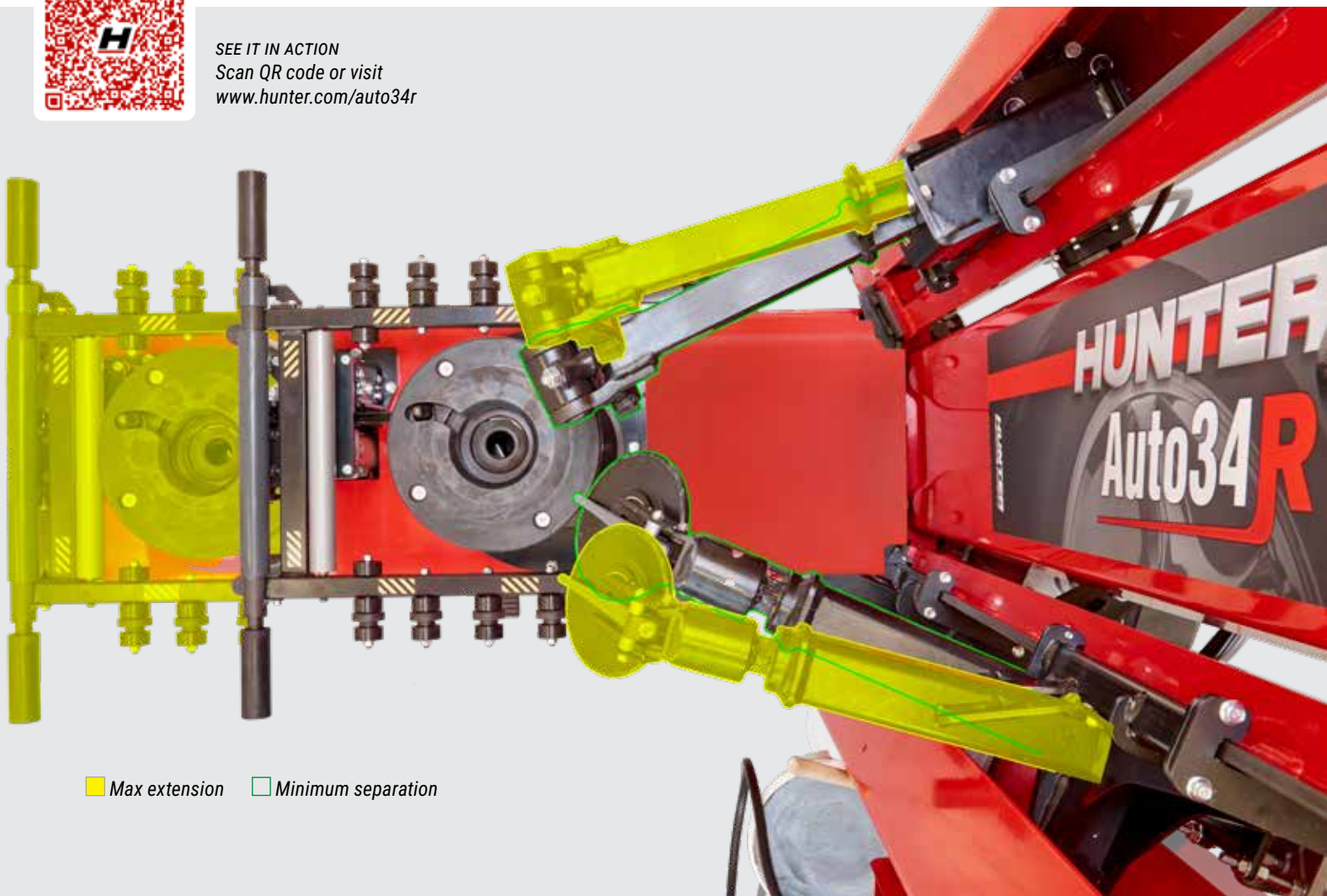

■ Max extension □ Minimum separation

PATENTED

Dynamic leverless tool head

Demounting Tool head inserts into tire, pulls bead over, and demounts in one fluid down/up motion.

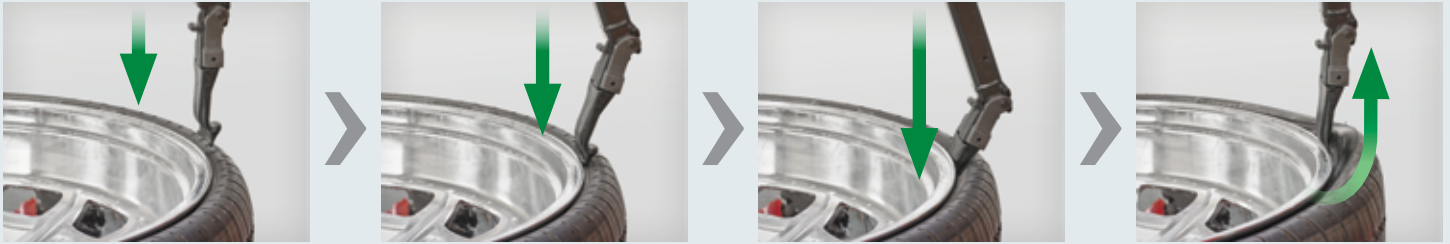

Mounting Thin, broad head alleviates stress on bead, and is durable enough to withstand immense mounting forces.

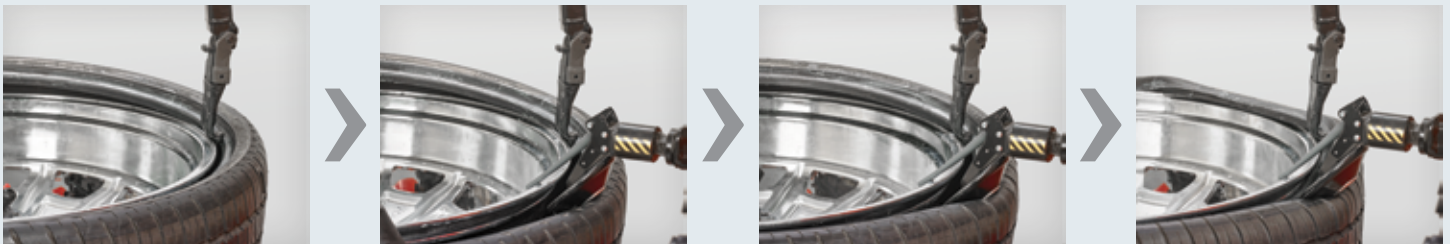

PATENTED

Versatile clamping system

- ✓ Adjusts to three working heights
- ✓ Handles wide range of rim diameters
- ✓ Cam action tightens as wheel turns
- ✓ Services reverse and standard wheels in same manner



Comfortable clamp handle reduces fatigue.



Three easily adjustable clamping heights provide the versatility you need.

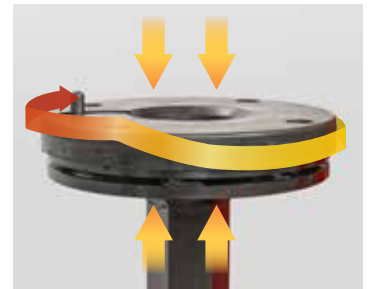

Cam plate rises to exert additional gripping force.



Rubber insert protects expensive reverse wheels.

TCA34R™ SPECIFICATIONS

Power requirements	208-230V, 6A, 60Hz, 1ph NEMA 20 amp plug, L6-20P
Air supply requirements	115-175 psi (8-12 bar)
Mount / demount tool	Self-inserting, polymer leverless head
Clamping type	Center w/Quick Clamp and cam plate
Bead loosening type	Upper and lower roller
Match-mounting capable	Yes
Adjustable clamping height	Yes
Rim diameter range	10-34 in.
Maximum tire diameter	65 in.
Maximum wheel width	19 in.
Drive	Variable up to 14 rpm CW, 7 rpm CCW
Torque	867 ft-lbs (1175 Nm)
Shipping weight	1172 lbs (531 kg)
Height	81" (2067 mm)
Width	59" (1494 mm)
Depth 1	65" (1651 mm) – chassis retracted
Depth 2	79" (2015 mm) – chassis extended

(see CS07881-00 for detailed specifications)



TCA34R

Full control
at the push of a button



Your local Hunter team is ready to help

- ✂ Receive same- or next-day service
- 📞 Get a free quote or on-site demo
- 📖 Register for ASE-accredited training courses
- 📄 General information and questions



Contact your local team

hunter.com/contact

Because of continuing technological advances, specifications, models and options are subject to change without notice.

Auto34R is a trademark of Hunter Engineering Company.

1124CH

Copyright © 2024, Hunter Engineering Company

HUNTER
Engineering Company

www.hunter.com

Form CB07864-00, 11/24

Supersedes Form CB07864-00, 07/24