

SMARTWEIGHT® ELITE

Wheel Balancer

HUNTER
Engineering Company

SPECIFICATIONS / FEATURES / DIMENSIONS []



Power Requirements	196-253V, 10 amp, 50/60 Hz, 1 ph NEMA L6-20 plug included
Air Supply Requirements	100-175 psi (7 - 12 bar)**
Approximate Air Consumption	4 CFM (110 Liters/Minute)
Rim Width Range	1.5 in to 20.5 in (38 mm to 521 mm)*
Rim Diameter Range	10 in to 30 in (254 mm to 762 mm)*
ALU	14 in to 40 in (356 mm to 1016 mm)*
Max. Tire Diameter	44 in (1118 mm)
Max. Tire Width	20 in (508 mm)
Max. Tire Weight	175 lbs (79 kg)
Radial & Lateral Runout Accuracy	0.002 in (0.051 mm)
Imbalance Resolution	± 0.01 oz (0.28 g)
Placement Accuracy	512 positions, ± 0.35°
Balancing Speed	300 rpm
Motor	Programmable drive system and DC motor
Usable Power Cord Length	~138 in. (3505 mm)

*Extreme wheel sizes may require manual data entry.

**Only wheel lift models and SpeedClamp®

SWE-	33	32	31	30	23	22	21	20	13	12	11	10	03	02	01	00
Wheel Lift	✓	✓	✓	✓					✓	✓	✓	✓				
SpeedClamp®	✓	✓	✓	✓	✓	✓	✓	✓								
TDC Laser†	✓	✓			✓	✓			✓	✓			✓	✓		
Printer & Shelf	✓		✓		✓		✓		✓		✓		✓		✓	
Width (W)	72 in 1829 mm	64 in 1626 mm	72 in 1829 mm	64 in 1626 mm	65 in 1651 mm	60.5 in 1537 mm	65 in 1651 mm	57 in 1448 mm	72 in 1829 mm	64 in 1626 mm	72 in 1829 mm	64 in 1626 mm	65 in 1651 mm	60.5 in 1537 mm	65 in 1651 mm	57 in 1448 mm
Height (H)	88.5 in 2248 mm	88.5 in 2248 mm	71 in 1804 mm	71 in 1804 mm	88.5 in 2248 mm	88.5 in 2248 mm	71 in 1804 mm	71 in 1804 mm	88.5 in 2248 mm	88.5 in 2248 mm	71 in 1804 mm	71 in 1804 mm	88.5 in 2248 mm	88.5 in 2248 mm	71 in 1804 mm	71 in 1804 mm
Depth (D)	63.5 in 1613 mm	63.5 in 1613 mm	63.5 in 1613 mm	63.5 in 1613 mm	63.5 in 1613 mm	63.5 in 1613 mm	63.5 in 1613 mm	63.5 in 1613 mm	63.5 in 1613 mm	63.5 in 1613 mm	63.5 in 1613 mm	63.5 in 1613 mm	63.5 in 1613 mm	63.5 in 1613 mm	63.5 in 1613 mm	63.5 in 1613 mm
Weight	575 lb 261 kg	522 lb 237 kg	525 lb 238 kg	472 lb 214 kg	474 lb 215 kg	421 lb 191 kg	424 lb 192 kg	371 lb 169 kg	575 lb 261 kg	522 lb 237 kg	525 lb 238 kg	472 lb 214 kg	474 lb 215 kg	421 lb 191 kg	424 lb 192 kg	371 lb 169 kg

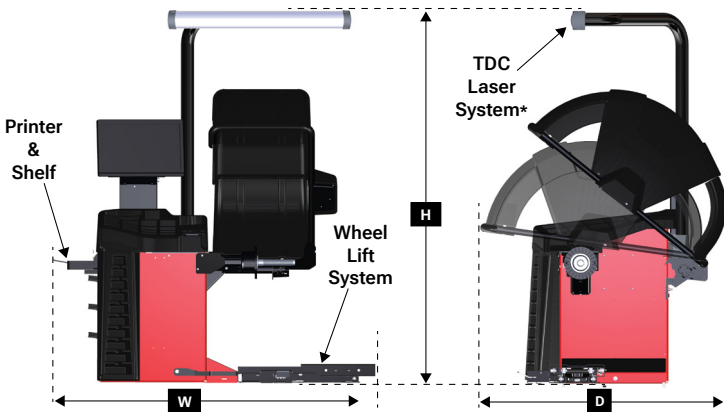

**SmartWeight® Elite model numbers are trademarks of Hunter Engineering Company

†When equipped with the TDC system, the balancer is a Class 2 laser product.



LASER RADIATION - DO NOT STARE INTO THE BEAM OR VIEW DIRECTLY WITH OPTICAL INSTRUMENTS.

Viewing the laser output with magnifiers or related optical instruments within a distance of 100 mm from the laser aperture may pose an eye hazard.

For balancer information visit:
hunter.com/wheel-balancers

For local contact visit:
hunter.com/contact

For general inquiries visit:
www.hunter.com or call 800-448-6848

Because of continuing technological advancements, specifications, models and options are subject to change without notice.

Form BS07722-00, 05-24
Supersedes Form BS07722-00, 06-21
Copyright ©2024, Hunter Engineering Company