

## SITE REQUIREMENTS

### TCRH, TCR1X & TCR1S

### HUNTER REVOLUTION™ TIRE CHANGER



TCRH



TCR1X

| TCRH/TCR1X / TCR1S      |  |
|-------------------------|--|
| Power Requirements      | 208-230V, 1 phase, 60Hz, 24A, NEMA 30 amp plug, L6-30P, 5,520 watts      |
| Air Supply Requirements | 125 ± 25 psi (8.6 ± 1.7 bar)   |
| Internet Requirements   | Hardwire, 10+mbps up and down  |
| Air Consumption         | 1 SCFM (27 L/Min)  |
| Shipping Weight         | 1,856 lbs (842 kg)   |
| Width (W)               | 52 in. (1,321 mm)  |
| Height (H1)             | TCR1S: 78.5 in. (1,994 mm), TCRH/TCR1X: 86 in. (2,184 mm)                |
| Height (H2)             | 75.5 in. (1,918 mm),   |
| Depth (D)               | 67 in. (1,702 mm) - Wheel Lift Up<br>78 in. (1,981 mm) - Wheel Lift Down |

## KEY SPECIFICATIONS

| TCR1S / TCR1X          |  |
|------------------------|--|
| Mount / Demount Tool   | Polymer Self Inserting Leverless                               |
| Clamping Type          | Center w/ Quick Clamp  |
| Bead Loosening Type    | Upper / Lower Roller   |
| Match Mounting Capable | Yes  |
| Rim Diameter Range     | 12 in. - 30 in. (305 mm - 762 mm)                              |
| Maximum Tire Diameter  | 50 in. (1,270 mm)  |
| Maximum Wheel Width    | 15 in. (381 mm)  |
| Drive                  | Variable up to 15 rpm CW / CCW<br>Torque: 875 ft-lbs (1186 Nm) |

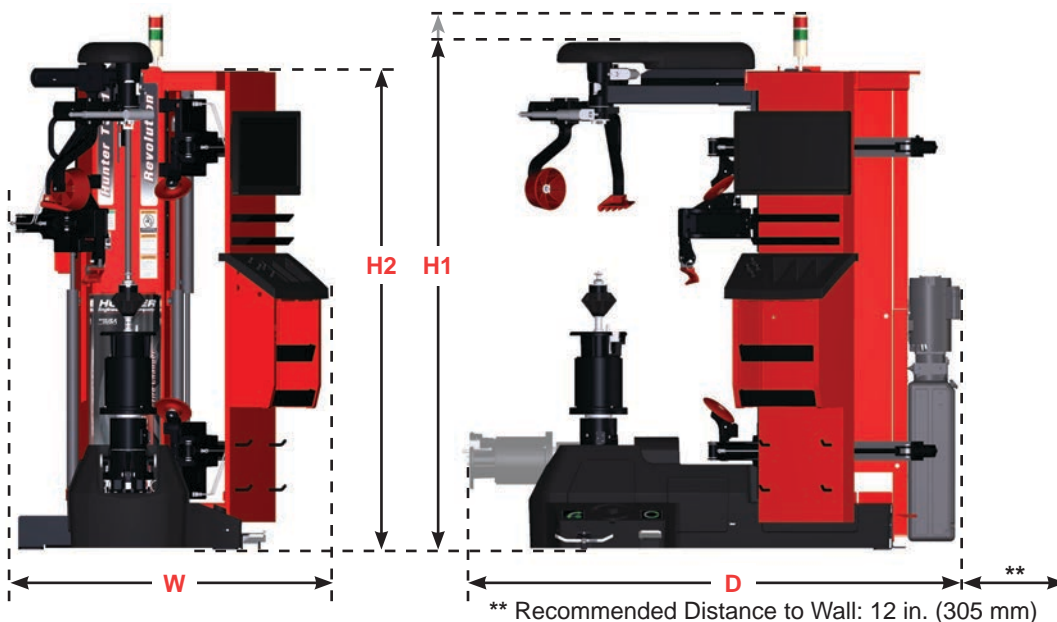

For tire changer information visit:  
[www.hunter.com/tire-changers](http://www.hunter.com/tire-changers)

For local contact visit:  
[www.hunter.com/contact-hunter](http://www.hunter.com/contact-hunter)

For general inquiries visit:  
[www.hunter.com](http://www.hunter.com) or call 800-448-6848