

SPECIFICATIONS []

SPECIFICATIONS	
Weight of Target	11 lbs. (5 kg)
Profile of Target	18 in. (457 mm)
Installation Time	10 - 15 seconds
Rolling Compensation Style	Back / Forward
Camera Resolution	2,608 x 1,952 / 10 million px
Track Width	80 in. (2032 mm)
Wheel Base	210 in. (5334 mm)
Distance to Wall	65 - 97 in. (1651 - 2464 mm)
Suggested Distance	97 in. (2464 mm)
Short Bay Distance (see site info)	65 in. (1651 mm)

MEASUREMENTS	
S.A.I. & Included Angle	✓
Set Back	✓
Max Steering Angle	To Lock
Wheelbase Difference	✓
Track Width Difference	✓
Lateral Offset	✓
Rear Set Back	✓
Axle Offset	✓

DIMENSIONS	
Width (W1)	36 in. (914 mm)
Width (W2)	105 in. (2667 mm)
Height (H1)	40 in. (1016 mm)
Height (H2)	122.5 in. (3112 mm)
Depth (D)	21 in. (534 mm)

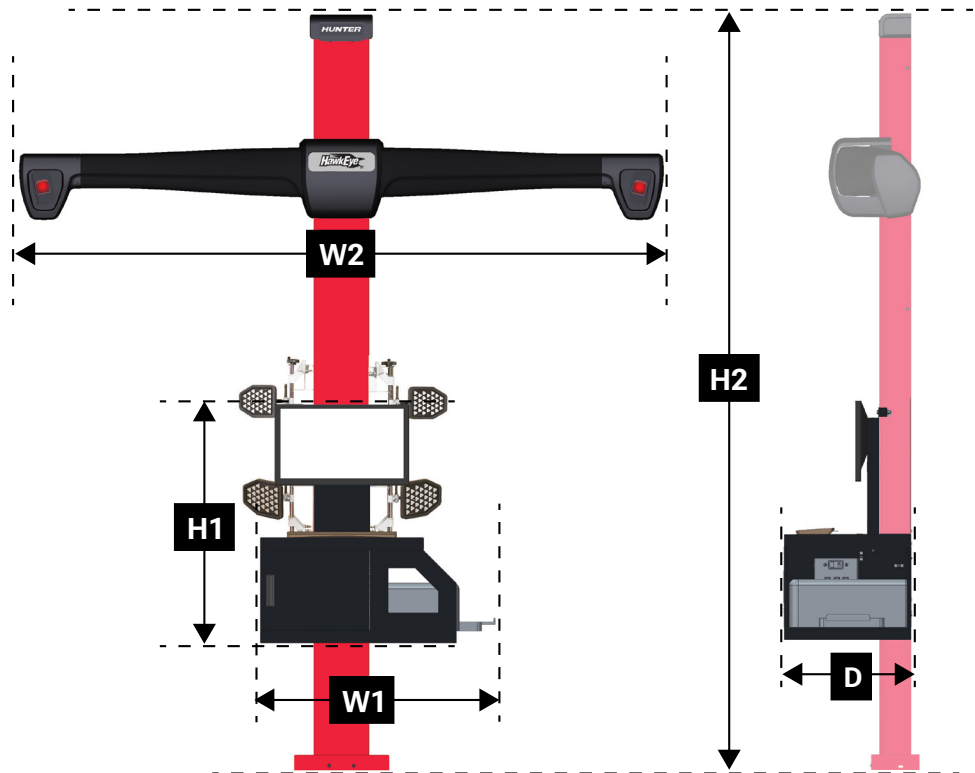

For alignment information visit:
hunter.com/alignment-machines

For local contact visit:
hunter.com/contact

For general inquiries visit:
www.hunter.com or call 800-448-6848